



# ***PARTS LIST***



## **18HP Models**

<b>Mfg. No.</b>	<b>Description</b>
2690891	LT150RDFR, 18HP 40" Hydro Lawn Tractor, Seco (2010)
2690916	LT150RD, 18HP 40" Hydro Lawn Tractor, Seco (2010)

**Manual Part No.** 1739896  
Revision B  
Rev. Date: 10/15/2010



<b>PRODUCT COMPONENTS</b>	<b>PAGES</b>
Frame & Front Axle Group .....	4
Steering Group .....	6
Engine Group - 18HP .....	8
Transmission SERVICE PARTS - Tuff Torq K46CW .....	10
Control Group .....	14
Electrical Group .....	18
Hood, Grille & Dash Group .....	22
Seat Deck & Fuel Tank Group .....	24
Mulching Group .....	26
Rear Discharge Deflector Group .....	28
Lift Group .....	30
Wheels & Tires Group .....	32
Decal Group .....	34
Back Plate Group .....	36
Collector Group .....	38
French Guard Group .....	40
40" Mower Deck - Belt & Idler Arm Group .....	42
40" Mower Deck - Housing, Hitch, Arbors & Blade Group .....	46
<b>Torque Specification Chart .....</b>	<b>Inside Back Cover</b>

## Frame & Front Axle Group

NOTE: Unless noted otherwise,  
use the standard hardware torque  
specification chart.

2988017

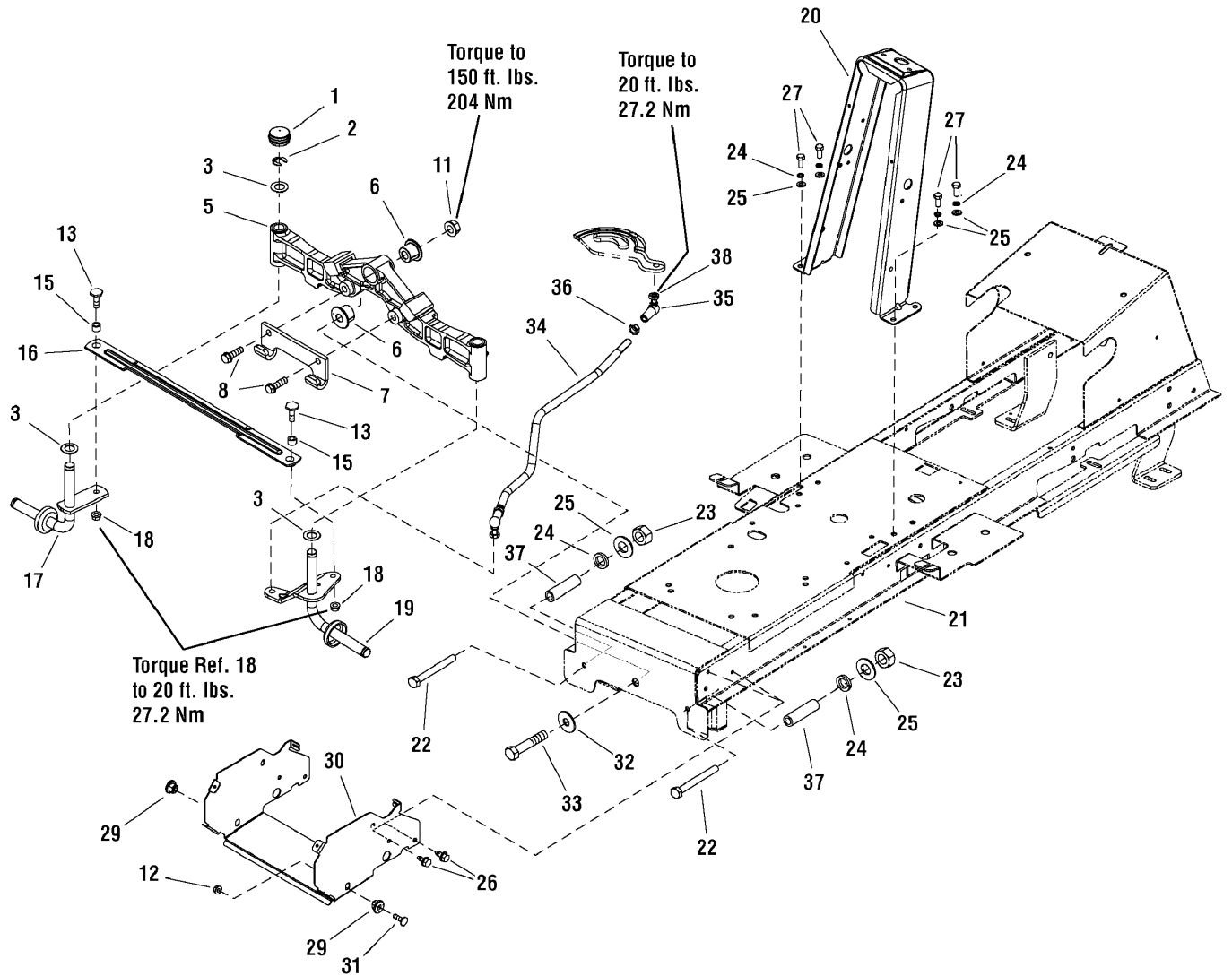

The above parts group applies to the following Mfg. Nos.:

2690891 - LT150RDFR

2690916 - LT150RD

## Frame & Front Axle Group

REF NO	PART NO.	QTY.	DESCRIPTION
1	1726504SM	2	CAP, Hub 1.51D
2	1611710SM	2	RING, Klipring
3	2860183SM	4	WASHER, 828 x 1.62 x .0583
5	1728018SM	1	AXLE, Front (Includes Ref. Nos. 1, 2, 3, 17 & 19)
6	1730186SM	2	BUSHING, Axle Pivot
7	1721918ASM	1	HOOK, Hitch, 5/16
8	1960652SM	2	CAPSCREW, 7/16-14 x 1-1/2
11	2860646SM	1	NUT, Hex Flange, 5/8-11
12	1931277SM	2	NUT, Hex Flange, 5/16-18
13	1960032SM	2	CAPSCREW, Hex 3/8-16 x 1-1/4
15	1731912SM	2	SPACER
16	1728080ASM	1	ROD, Tie
17	1727872ASM	1	SPINDLE AND CUP ASSEMBLY, Right
18	1930645SM	2	NUT, Hex Flange, 3/8-16
19	1727873ASM	1	SPINDLE AND CUP ASSEMBLY, Left
20	1727260SM	1	TOWER
21	1736499YP	1	FRAME
22	1735874YP	2	BOLT, M8 x 75
23	1735934YP	2	NUT, M8
24	1735989YP	6	WASHER, 8.4
25	1736000YP	6	WASHER, 8
26	1930601SM	4	SCREW, Tap 5/16-18 x 5/8
27	1735868YP	4	BOLT, M8 x 20
29	1728086SM	2	PIVOT, Hood
30	1735973YP	1	SUPPORT, Muffler
31	1931335SM	2	BOLT, Round Head, 5/16-18 x 1
32	1960035SM	1	WASHER, 5/8
33	2860744SM	1	CAPSCREW, Hex 5/8-11 x 3-1/4
34	1735919YP	1	DRAG LINK
35	1735851YP	2	BALL JOINT, CS16 M10-M12
36	1735928YP	2	NUT, M12
37	1735892YP	2	DISTANCE, Front Axle 0-9521-291
38	1735926YP	2	NUT, M10

### Footnotes

The above parts group applies to the following Mfg. Nos.:

2690891 - LT150RDFR

2690916 - LT150RD

## Steering Group

NOTE: Unless noted otherwise,  
use the standard hardware torque  
specification chart.

2988025

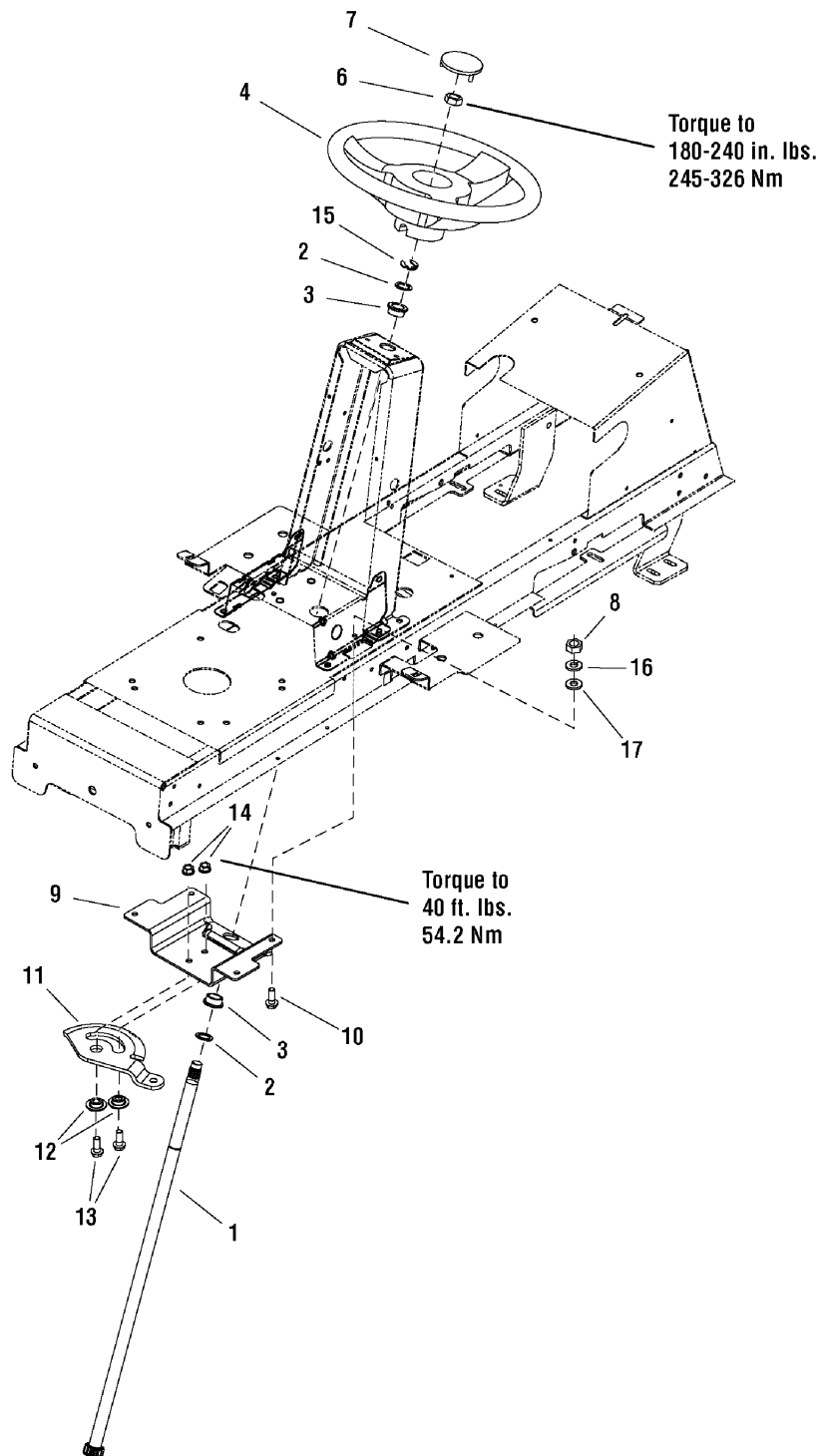

The above parts group applies to the following Mfg. Nos.:

2690891 - LT150RDFR

2690916 - LT150RD

## Steering Group

REF NO	PART NO.	QTY.	DESCRIPTION
1	1727813SM	1	SHAFT, Steering Gear & Spline
2	1960114SM	2	WASHER, 3/4
3	1729665SM	2	BUSHING
4	1728069SM	1	STEERING WHEEL
6	1960576SM	1	NUT, Hex-Lock 5/8-18
7	1725024SM	1	CAP, Steering Wheel
8	1735934YP	4	NUT, M8
9	1727940SM	1	BRACKET, Sector Support
10	1735870YP	4	BOLT, M8 x 25
11	1728027SM	1	GEAR, Steering .250 THK 26 Teeth
12	1728122SM	2	SPACER, Sector Gear
13	1934654SM	2	SCREW, Hex LK Flange 3/8-16 x 1.00
14	1931211SM	2	NUT, Hex-Flange 3/8-16 LK
15	1611710SM	1	RING, Klipring
16	1735989YP	4	WASHER, 8.4
17	1736000YP	4	WASHER, 8

## Footnotes

---

**The above parts group applies to the following Mfg. Nos.:**

2690891 - LT150RDFR

2690916 - LT150RD

## Engine Group - 18HP

NOTE: Unless noted otherwise,  
use the standard hardware torque  
specification chart.

2988771

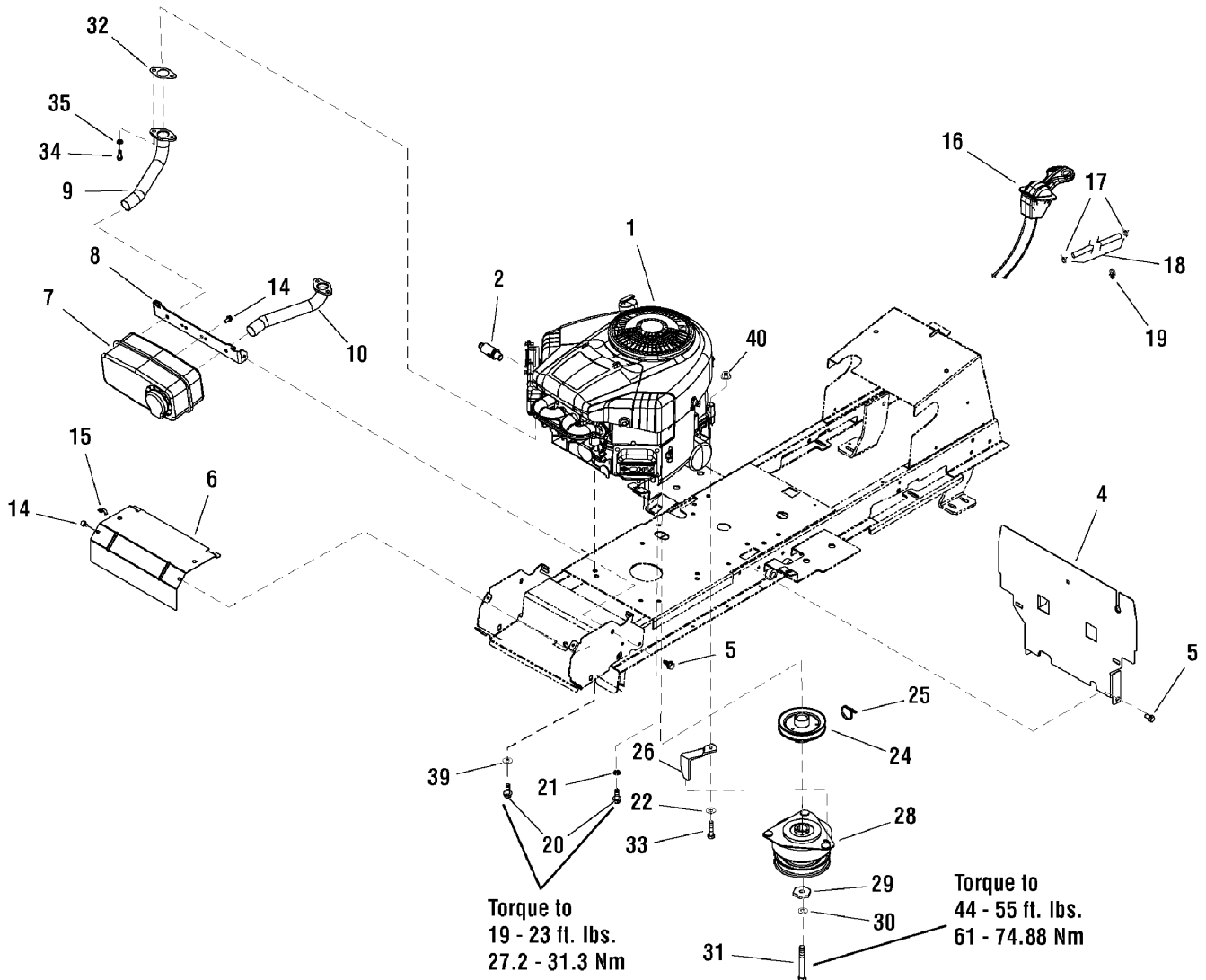

The above parts group applies to the following Mfg. Nos.:

2690891 - LT150RDFR

2690916 - LT150RD

## Engine Group - 18HP

REF NO	PART NO.	QTY.	DESCRIPTION
1	405577-0130-B1	1	* ENGINE, 18HP Briggs & Stratton, V-Twin Intek (Engine Model: 405577-0130-B1)
2	1717473SM	1	VALVE, Shut Off Oil Drain
4	1735962YP	1	SHIELD, Heat Change
5	1930601SM	4	CAPSCREW, Hex Washer Head, Taptite, 5/16-18 x 5/8
6	1727997ASM	1	HEAT SHIELD, Engine
7	1727994SM	1	MUFFLER, Twin
8	1727976ASM	1	SUPPORT, Muffler
9	1727979SM	1	PIPE, Exhaust
10	1727980SM	1	PIPE, Exhaust
14	1925003SM	4	CAPSCREW, Hex Washer Head, Taptite, 1/4-20 x 1/2
15	2834683SM	1	CLIP, Wire
16	1734505SM	1	CONTROL, Throttle
17	1736993YP	2	CLAMP
18	1735913YP	1	HOSE, Fuel
19	1730268SM	2	CLIP, Hose
20	1736994YP	2	CAPSCREW, M8 x 35
21	2820427SM	1	LOCKWASHER, External Tooth, 3/8
22	1736995YP	1	WASHER, 9
24	1732576SM	1	PULLEY & HUB ASSEMBLY, Engine
25	1735980YP	1	TIE
26	1732875SM	1	RETAINER, Clutch
28	1736105SM	1	CLUTCH, Electric
29	1708264SM	1	WASHER, Hex
30	1918199SM	1	LOCKWSHER, Spring, 7/16
31	1960649SM	1	CAPSCREW, Hex Head, 7/16-20 x 3-1/2
32	1731214SM	2	GASKET, Exhaust
33	1736996YP	2	CAPSCREW, M8 x 45
34	1936228SM	4	CAPSCREW, Hex Socket Head, 5/16-18 x 3/4
35	1917356SM	4	LOCKWASHER, Spring, 5/16
39	1736999YP	4	WASHER, 8.4
40	1737000YP	4	NUT, 8

### Footnotes

Note\* For information on Replacement Parts contact the engine manufacturer.

---

### The above parts group applies to the following Mfg. Nos.:

2690891 - LT150RDFR  
2690916 - LT150RD

# Transmission SERVICE PARTS - Tuff Torq K46CW

**NOTE:** Unless noted otherwise,  
use the standard hardware torque  
specification chart.

1735476

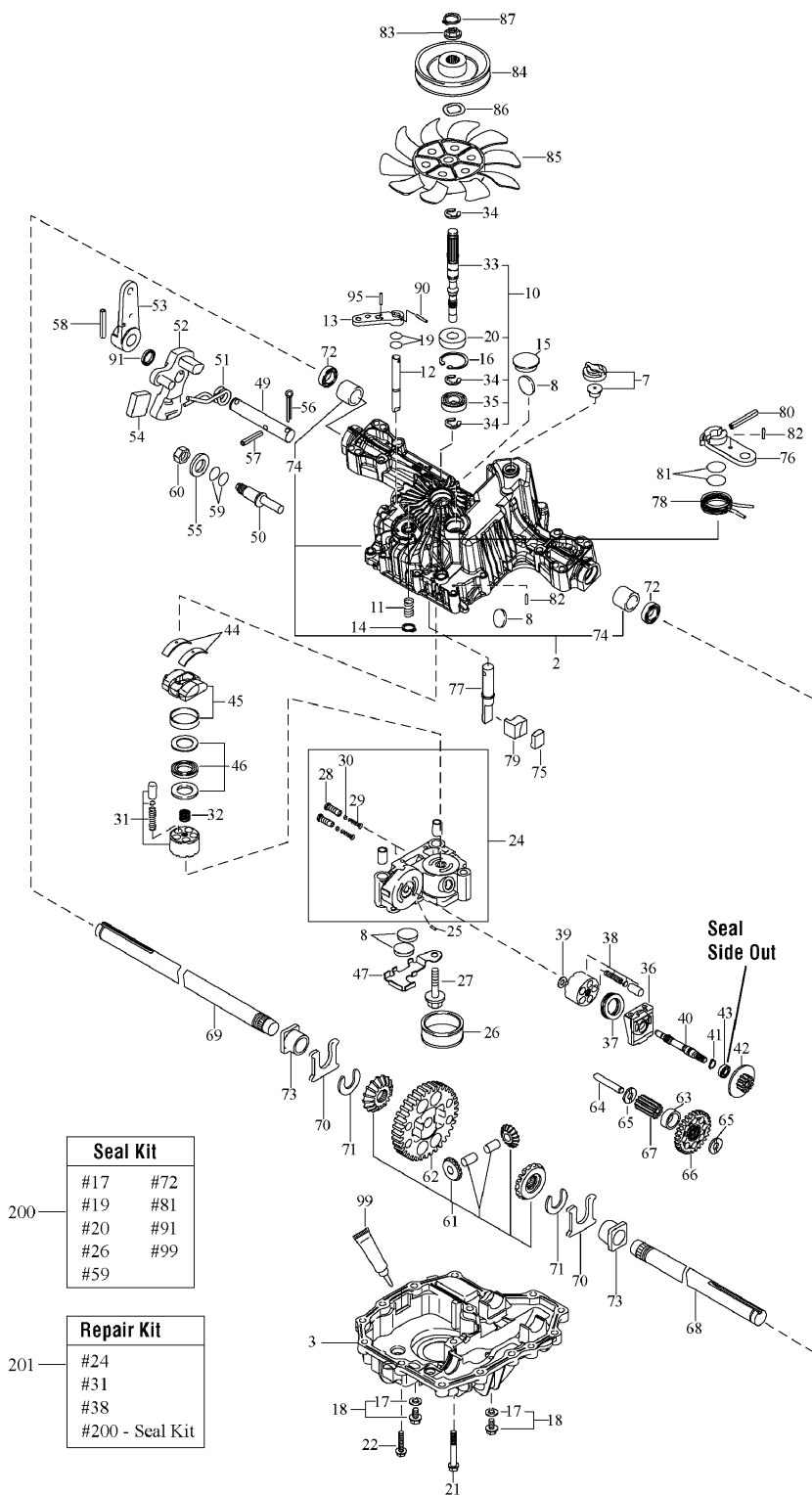

**The above parts group applies to the following Mfg. Nos.:**

- 2690891 - LT150RDFR
- 2690916 - LT150RD

## Transmission SERVICE PARTS - Tuff Torq K46CW

REF NO	PART NO.	QTY.	DESCRIPTION
--	1735476YP		TRANSMISSION, Tuff Torq, K46CW
2	-----		*KIT, Upper Case
3	1724278SM		LOWER CASE
7	1739891YP		VENT VALVE
8	1724279SM		MAGNET
10	-----		*KIT, Pump Shaft / Bearing
11	-----		*SPRING 25
12	-----		*BYPASS SHAFT
13	1720418SM		LEVER, Bypass
14	-----		*RING, Snap, 10
15	1724282SM		SEALING CAP, 30
16	1708650SM		SNAP RING, C 35
17	1724323YP		SEAL WASHER, 8
18	-----		*KIT, Drain Bolt
19	1708691SM		O-RING 1A P10A
20	1708651SM		SEAL TC 153507
21	-----		*SCREW, Tapping, 8 * 55
22	1707789SM		SCREW, Tapping, 8 * 30
24	-----		*KIT, Center Case
25	1718070SM		PIN 3 * 9.8
26	-----		*FILTER 105
27	-----		*BOLT 10 * 75
28	-----		*IDS VALVE 1.2
29	-----		*IDS SPRING
30	-----		*IDS FILTER 300
31	1725831SM		KIT, Cylinder Block (Pump)
32	1724290SM		SPRING
33	1739892YP		PUMP SHAFT
34	1718076SM		E-RING, 15
35	1708673SM		BEARING, 6202C3
36	1718077SM		MOTOR HOUSING
37	-----		*THRUST BEARING 51106
38	-----		*KIT, Cylinder Block (Motor)
39	1718074SM		WASHER, 12 * 24 * 1
40	1724943SM		MOTOR SHAFT
41	1708672SM		SNAP RING, S15
42	1724944SM		BRAKE DISC/MOTOR GEAR (10T)
43	1718083SM		BEARING, 6202
44	1718089SM		THRUST METAL
45	-----		*SWASH PLATE CMP
46	-----		*THRUST BEARING (PUMP) KIT
47	-----		*MAGNET HOLDER
49	-----		*CONTROL SHAFT

### Footnotes

\*Note: See your local authorized dealership for parts and warranty or contact Tuff Torq at [www.tufftorqservices.com](http://www.tufftorqservices.com) (U.S. 1-866-572-3441 Int'l 01-423-585-1977)

### The above parts group applies to the following Mfg. Nos.:

2690891 - LT150RDFR  
2690916 - LT150RD

# Transmission SERVICE PARTS - Tuff Torq K46CW

NOTE: Unless noted otherwise,  
use the standard hardware torque  
specification chart.

1735476

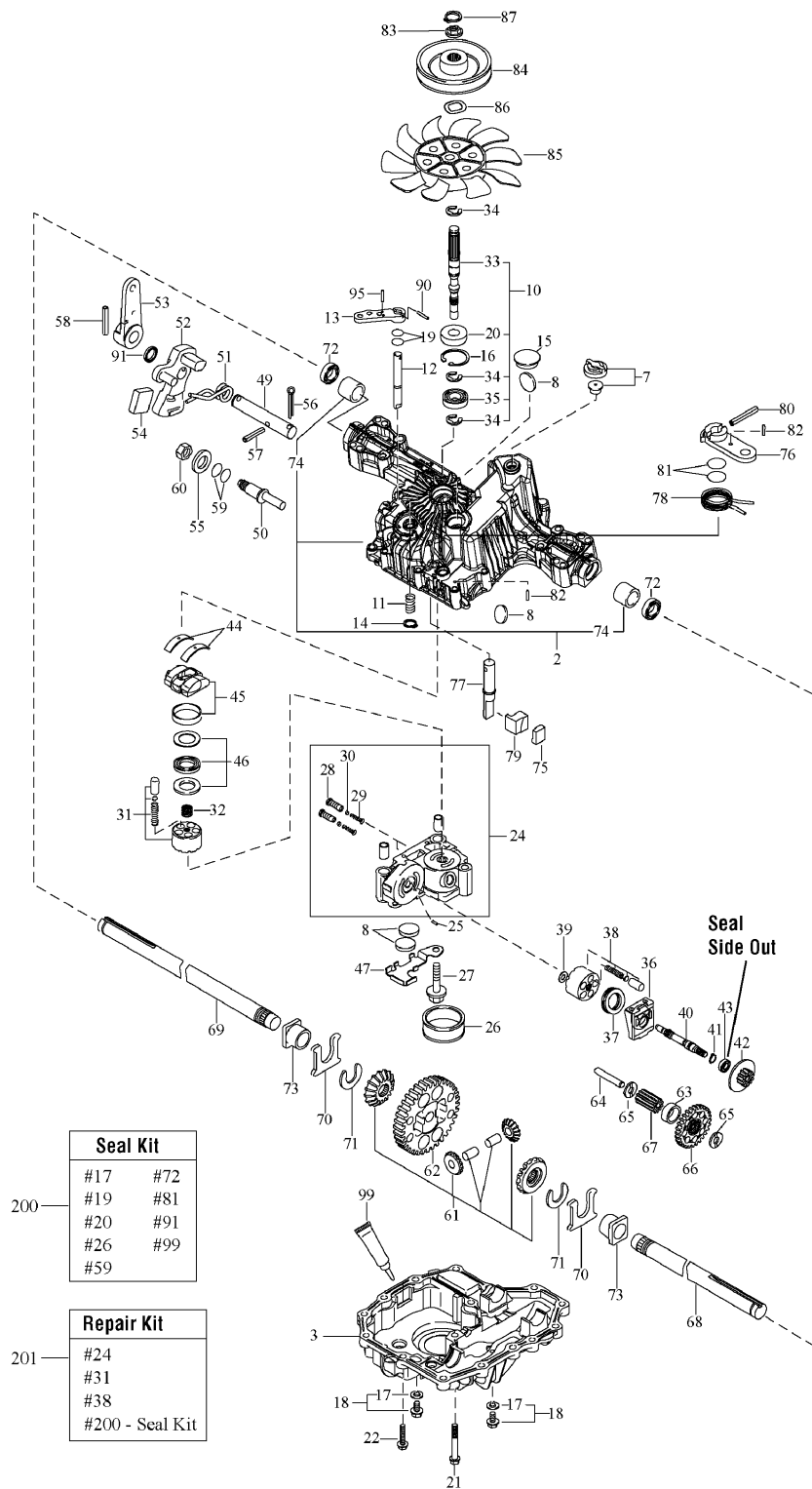

Seal Kit	
#17	#72
#19	#81
#20	#91
#26	#99
#59	

Repair Kit	
#24	
#31	
#38	
#200	- Seal Kit

The above parts group applies to the following Mfg. Nos.:

- 2690891 - LT150RDFR
- 2690916 - LT150RD

## Transmission SERVICE PARTS - Tuff Torq K46CW

REF NO	PART NO.	QTY.	DESCRIPTION
54	----		*JERKY PLATE
55	----		*WASHER 12
56	----		*COTTER PIN 1/8 * 3/4
57	----		*SPRING PIN 6 * 36
58	1960588SM		ROLL PIN 6 * 40
59	1707879SM		O-RING 1A P14
60	----		*NUT 12
61	----		*KIT, Differential Gear
62	----		*FINAL GEAR (54T)
63	----		*FINAL PINION COLLAR
64	----		*REDUCTION SHAFT
65	1724948SM		WASHER, 12 * 32 * 32
66	1724949SM		REDUCTION GEAR (38T)
67	----		*FINAL PINION GEAR (10T)
68	1724303SM		AXLE SHAFT, Left
69	1724304SM		AXLE SHAFT, Right
70	1718112SM		THRUST WASHER
71	1718113SM		RING, 17
72	1718111SM		SEAL, 19 * 32 * 8
73	1718110SM		BUSHING, 19 * 25
74	----		*BUSHING 19.05
75	1724305SM		BRAKE SHOE
76	1724306SM		BRAKE LEVER
77	----		*BRAKE SHAFT
78	----		*BRAKE RETURN SPRING
79	1724309SM		BRAKE ACTUATOR
80	1724310SM		SPRING PIN, 5 * 32
81	1708690SM		O-RING 1A P12
82	----		*SPRING PIN 4 * 16
83	1724312SM		SPLINE COLLAR
84	1739893YP		PULLEY C
85	1724314SM		FAN, White
86	1724315SM		WASHER, Wave
87	1724316SM		RING, Snap
90	1707839SM		SPRING PIN, 3.0A * 20
91	1724318SM		OIL SEAL 16 * 22 * .03
95	----		*SPRING PIN 3.0A * 16
99	----		*SEALANT
200	1739894YP		SEAL KIT (K46 & T40)
201	----		*KIT, Repair, K46 (CE,CR)

### Footnotes

\*Note: See your local authorized dealership for parts and warranty or contact Tuff Torq at [www.tufftorqservices.com](http://www.tufftorqservices.com) (U.S. 1-866-572-3441 Int'l 01-423-585-1977)

---

### The above parts group applies to the following Mfg. Nos.:

2690891 - LT150RDFR  
2690916 - LT150RD

# Control Group

NOTE: Unless noted otherwise,  
use the standard hardware torque  
specification chart.

2988009

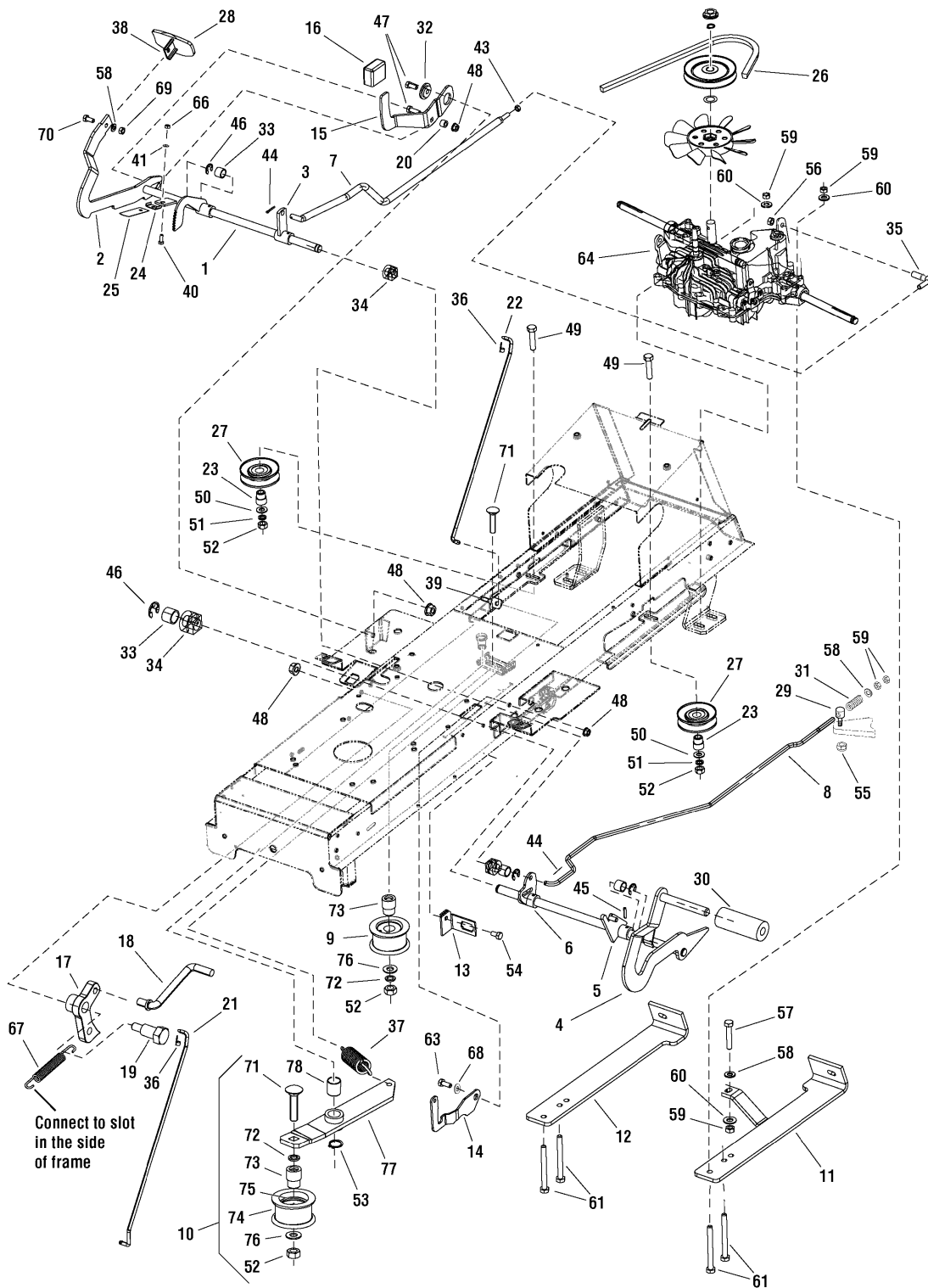

The above parts group applies to the following Mfg. Nos.:

2690891 - LT150RDFR

2690916 - LT150RD

## Control Group

REF NO	PART NO.	QTY.	DESCRIPTION
1	1735940YP	1	PEDAL, Forward
2	1735952YP	1	RATCHET
3	1735847YP	1	ARM
4	1735941YP	1	PEDAL, Brake
5	1735918YP	1	LEVER, Parking Brake
6	1735917YP	1	LEVERe, Brake
7	1735959YP	1	ROD, Traveling
8	1735957YP	1	ROD, Brake
9	1735951YP	1	PULLEY, Tensioning
10	1735950YP	1	PULLEY, Idler (Includes References: 52, 71, 72, 73, 74, 75, 76, 77, & 78)
11	1735910YP	1	HOLDER, Left
12	1735911YP	1	HOLDER, Right
13	1735974YP	1	SUPPORT, Switch
14	1735595ASM	1	LATCH, Brake Lock
15	1727246SM	1	PEDAL, Reverse
16	1727259SM	1	PAD, Foot Pedal
17	1727897SM	1	LATCH, Cruise
18	1727899SM	1	ROD, Cruise 5/16 dia. x 2.83"
19	1728976SM	1	BOLT, Shoulder 5/16-18 x 1-5/8
20	1728024SM	1	SPACER, Foot Pedal
21	1727898SM	1	ROD, Cruise, Latch, Upper
22	1727267SM	1	ROD, 1/4 dia x 15.95"
23	1735880YP	2	BUSHING, 0-9421-418
24	1736001YP	1	WASHER, Lock
25	1735972YP	1	SPRING, Flat 0-9740-221
26	1735987YP	1	V-BELT, 13 x 2580 Li BBT
27	1735949YP	2	PULLEY, Compensa C-00237/1
28	1735942YP	1	PEDAL, Forward Rubber
29	1735853YP	1	BOLT, 0-9016-447
30	1727261SM	1	PEDAL, Brake Pad
31	1735968YP	1	SPRING, TLZ 250.150.0530 Yellow
32	1727935SM	1	SPACER, Pivot
33	1735896YP	4	DISTANCE, Pedal 0-9521-288
34	1735881YP	4	BUSHING, 0-9462-202
35	1735850YP	1	BALL JOINT, CS 13 DIN 71802 M8 Silver
36	1728111SM	2	CLIP LINKAGE, 1/4 dia
37	1735969YP	1	SPRING, TZ 2x14 x 62 Yellow
38	1735943YP	1	PEDAL, Forward Top
39	1735875YP	1	BOLT, Eye M6 x 80 BN1006
40	1735866YP	1	BOLT, M6 x 16
41	1735998YP	2	Washer 6.4
43	1735936YP	1	NUT, M8
44	1735963YP	2	SPINDLE, 2 x 20

### Footnotes

The above parts group applies to the following Mfg. Nos.:

2690891 - LT150RDFR

2690916 - LT150RD

# Control Group

NOTE: Unless noted otherwise,  
use the standard hardware torque  
specification chart.

2988009

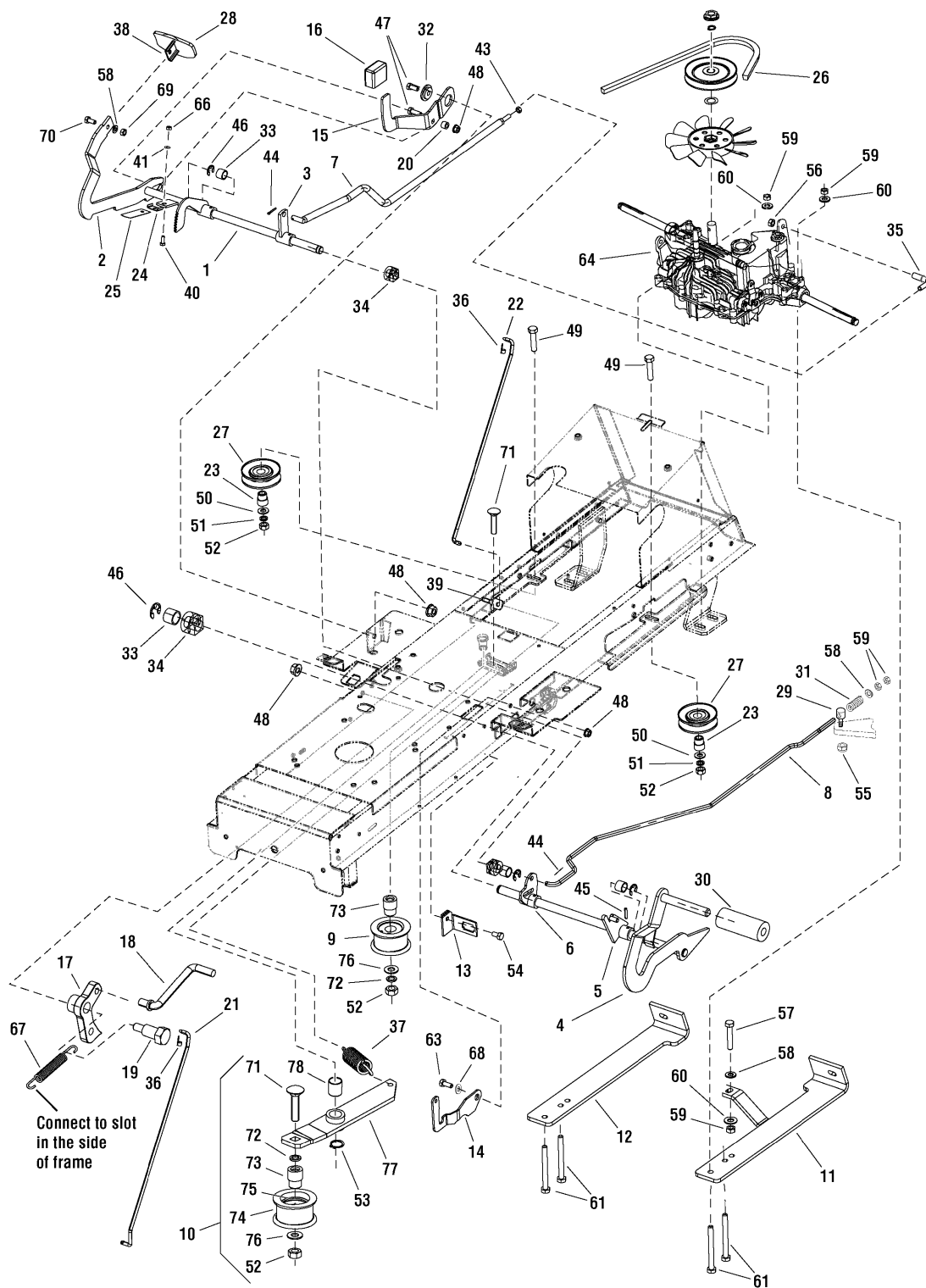

The above parts group applies to the following Mfg. Nos.:

2690891 - LT150RDFR

2690916 - LT150RD

## Control Group

REF NO	PART NO.	QTY.	DESCRIPTION
49	1735855YP	2	BOLT, M10 x 40
50	1735990YP	2	WASHER, 10.5
51	1735991YP	2	WASHER, 10
52	1735925YP	4	NUT, M10
53	1735921YP	1	LOCK RING
54	1930601SM	1	SCREW, Tap 5/16-18 x 5/8
55	1735924YP	1	NUT, M10
56	1735938YP	1	NUT, M8
57	1735873YP	1	BOLT, M8 x 45
58	1735989YP	7	WASHER, 8.4
59	1735934YP	7	NUT, M8
60	1736000YP	5	WASHER, 8
61	1735874YP	4	BOLT, M8 x 75
63	1729576SM	1	BOLT, Shoulder 5/16-18 x 1.15
64	1735476SM	1	TRANSMISSION, Tuff Torq, K46CW
66	1735933YP	3	NUT, M6
67	2159181SM	1	SPRING
68	1735994YP	3	WASHER, 14 x 26/0.2
69	1735935YP	1	NUT, M8
70	1735854YP	1	BOLT, M8 x 16
71	1736455YP	2	SCREW, M10 x 45
72	1736456YP	2	LOCK RING, 40
73	1736457YP	2	BUSHING, Pulley, Tension
74	1736458YP	1	PULLEY
75	1736459YP	1	BALL BEARING, Pulley
76	1736460YP	2	WASHER, 11
77	1736461YP	1	ARM, Pulley, Tension
78	1736462YP	1	BEARING, Slide

## Footnotes

---

**The above parts group applies to the following Mfg. Nos.:**

2690891 - LT150RDFR

2690916 - LT150RD

# Electrical Group

NOTE: Unless noted otherwise, use the standard hardware torque specification chart.

2988014

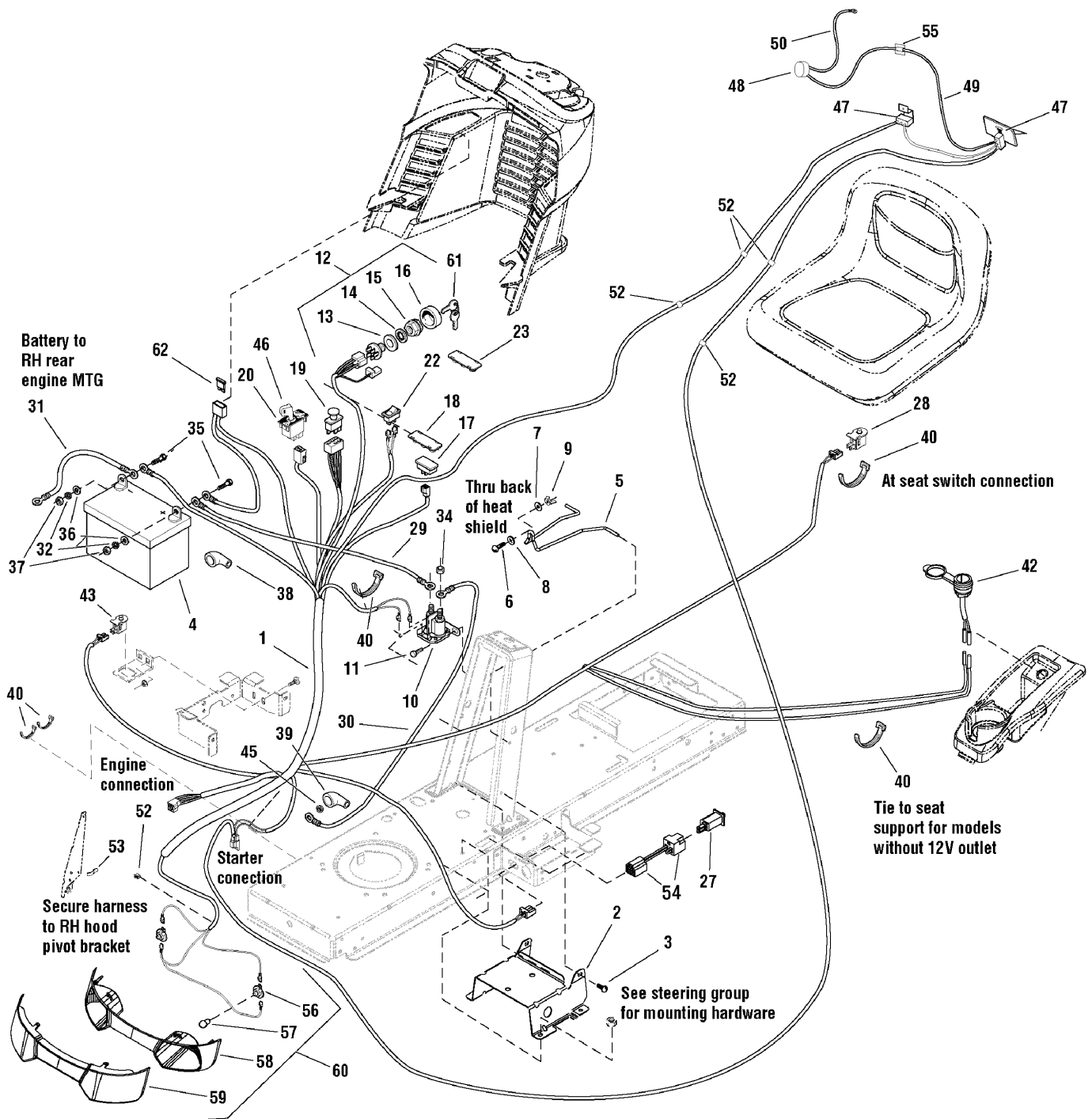

The above parts group applies to the following Mfg. Nos.:

2690891 - LT150RDFR

2690916 - LT150RD

## Electrical Group

REF NO	PART NO.	QTY.	DESCRIPTION
1	1736864YP	1	HARNESS, Main
2	1727282SM	1	SUPPORT, Battery
3	1930601SM	4	SCREW, Hex Washer Head, Taptite, 5/16-18 x 5/8
4	1685215SM	1	BATTERY, 12V 230 CCA DRY
5	1730007SM	1	HOLD DOWN, Battery
6	1931318SM	1	BOLT, Carriage, 1/4-20 X 7/8
7	1960353SM	1	WASHER, Flat, 1/4
8	1960518SM	1	PUSHNUT, 1/4
9	1920397SM	1	NUT, ESNA, 1/4
10	1728963SM	1	SOLENOID, 12V
11	1925003SM	2	SCREW, Hex Washer Head, Taptite, 1/4-20 x 1/2
12	1716061YP	1	SWITCH ASSEMBLY, Ignition (Includes References 13, 14, 15, & 16)
13	2101025SM	1	WASHER, 5/8
14	1960547SM	1	LOCKWASHER, Int. Tooth .62
15	1717549SM	1	NUT, Hex Flange, Ignition Switch 5/8-32
16	1717550SM	1	COVER, Ignition Switch
18	1729993SM	1	PLUG, Hour Meter
19	1722887SM	1	SWITCH, PTO
20	1726556SM	1	SWITCH, RMO Module Only
22	1716951SM	1	SWITCH, Head lights
23	1722611SM	1	PLUG
27	1732006SM	1	SWITCH, Push (Foot Pedal)
28	1732005SM	1	SWITCH, Push NC (Seat)
29	1716549SM	1	CABLE, #6 10.0 Lg Red
30	1721830SM	1	CABLE, #6 25.0 Lg Red
31	1713163SM	1	CABLE, #6 20.0 Lg Black
32	2816964SM	2	LOCKWASHER, Spring, 1/4
34	2860750SM	2	NUT, Hex KEPS, 5/16-24
35	2823341SM	2	CAPSCREW, Hex 1/4-20 x 3/4
36	2821319SM	2	WASHER, Flat, 1/4
37	2816622SM	2	NUT, Hex, 1/4-20
38	1677296SM	1	BOOT, Insulator, Battery
39	1713535SM	1	BOOT, Insulator, Red
40	1735980YP	5	TIE, RT 360 /L=150/
42	7073090SM	1	PLUG, Aux, 12V, (With Cover)
43	1732004SM	1	SWITCH, NO (RMO)
45	1960294SM	1	NUT, Flange, Whiz 1/4-20
46	1726557SM	1	KEY, RMO Module Plastic
47	1735922YP	2	MICROSWITCH, MKH 12 D13 S1
48	1735852YP	1	BEEPER, PF 27 A 29 EP
49	1736002YP	1	WIRE, 9-8316-615
52	1735882YP	7	CABLE CLIP
53	2834683SM	1	CLIP, Speed Wire

### Footnotes

The above parts group applies to the following Mfg. Nos.:

2690891 - LT150RDFR

2690916 - LT150RD

# Electrical Group

NOTE: Unless noted otherwise, use the standard hardware torque specification chart.

2988014

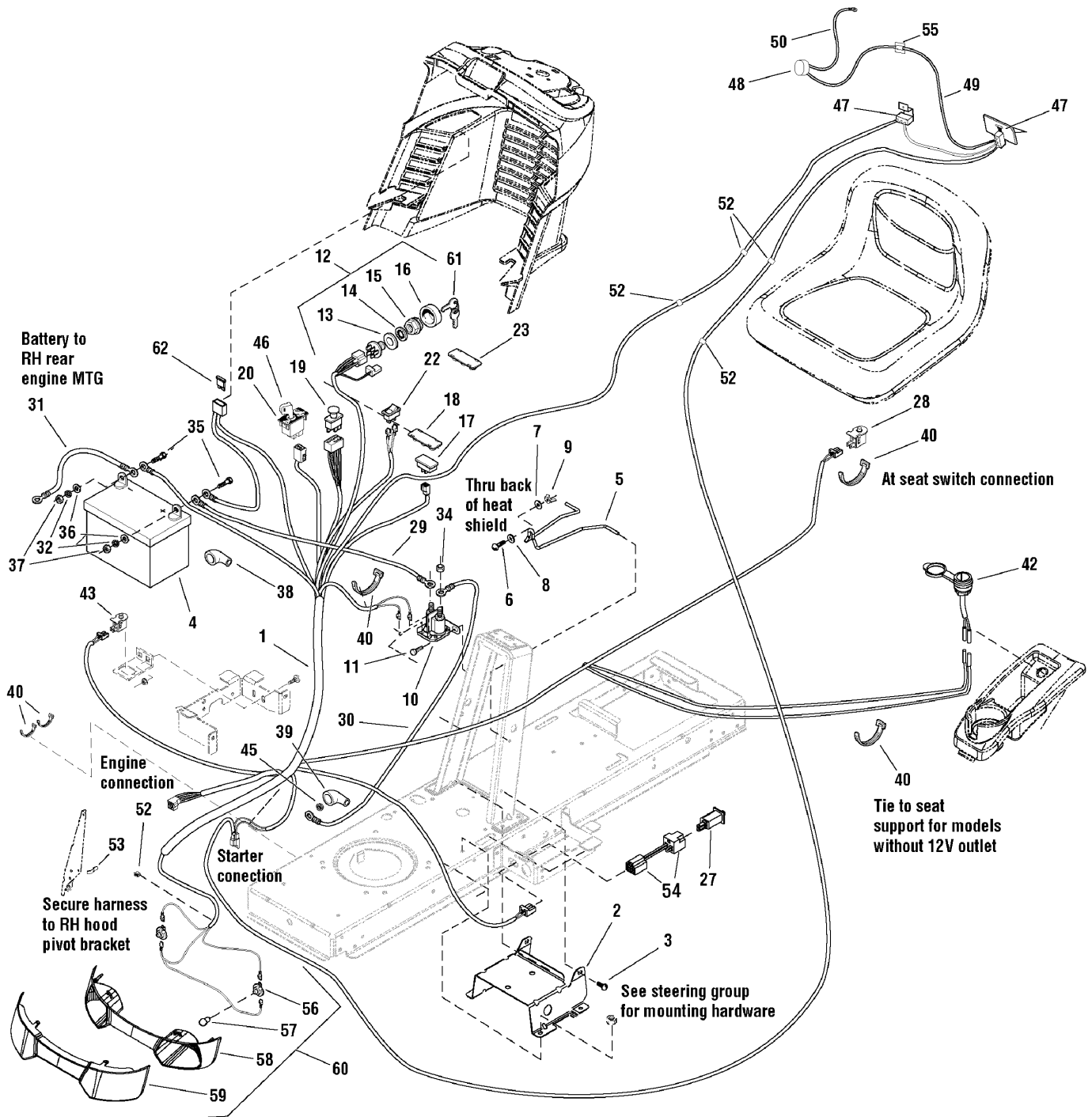

The above parts group applies to the following Mfg. Nos.:

2690891 - LT150RDFR

2690916 - LT150RD

## **Electrical Group**

---

<b>REF NO</b>	<b>PART NO.</b>	<b>QTY.</b>	<b>DESCRIPTION</b>
56	1723451SM	2	SOCKET ASSEMBLY
57	1677371SM	2	BULB, 1141-12V 21CP
58	1728973SM	1	REFLECTOR, Headlight
59	1728974SM	1	LENS, Headlight
60	1727296SM	1	HEADLIGHT ASSEMBLY (Includes References 56, 57, 58 & 59)
61	1717163SM	1	KEY, Ignition (Set of 2)
62	1731957SM	1	FUSE

### **Footnotes**

---

**The above parts group applies to the following Mfg. Nos.:**

2690891 - LT150RDFR

2690916 - LT150RD

## Hood, Grille & Dash Group

NOTE: Unless noted otherwise,  
use the standard hardware torque  
specification chart.

2988879

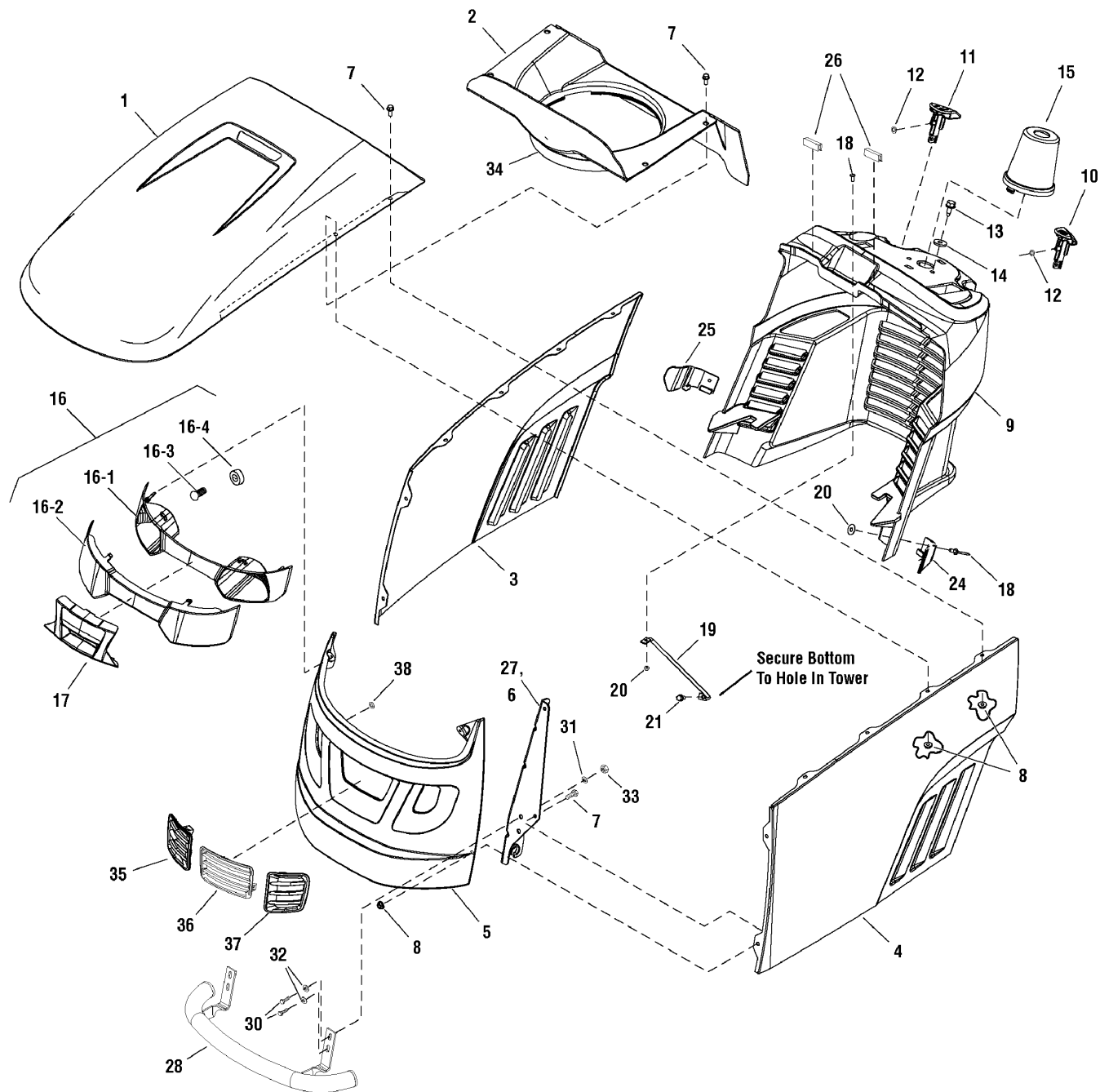

The above parts group applies to the following Mfg. Nos.:

2690891 - LT150RDFR

2690916 - LT150RD

## Hood, Grille & Dash Group

REF NO	PART NO.	QTY.	DESCRIPTION
1	1728031BIYP	1	HOOD, Black
2	7102326YP	1	DUCT, Air Inlet
3	1727294BIYP	1	PANEL, Side, R.H.
4	1727295BIYP	1	PANEL, Side, L.H.
5	1738914BIYP	1	GRILLE, Black
6	1727279ASM	1	HINGE, Hood, L.H.
7	1960295SM	12	CAPSCREW, Hex Flange Whiz Lock, 1/4-20 x 5/8
8	1930641SM	12	NUT, Hex Flange, Whiz Lock, 1/4-20
9	1739105YP	1	CONSOLE
10	1728089SM	1	KNOB, Brake Lock
11	1728090SM	1	KNOB, Cruise Lock
12	1960518SM	2	PUSHNUT, 1/4
13	1664847SM	2	CAPSCREW, Hex Washer Head, Taptite, 5/16-18 x 3/4
14	1919381SM	2	WASHER, 5/16
15	1727999SM	1	COVER, Steering Shaft
16	1727296SM	1	HEADLIGHT ASSEMBLY, Complete (Includes Ref. Nos. 16-1, 16-2, 16-3 & 16-4)
16-1	1728973SM	1	REFLECTOR
16-2	1728974SM	1	LENS
16-3	1677371SM	2	BULB, 12V
16-4	1723451SM	2	SOCKET
17	1728975SM	1	INSERT, Lightbar
18	1960392SM	3	SCREW, Pan Head Phillips, #10-24 x 1/2
19	1723123SM	1	ROD, Dash Support, 10"
20	1933896SM	3	NUT, Nylon Insert Lock, 10-24
21	1925003SM	1	CAPSCREW, Hex Washer Head, Taptite, 1/4-20 x 1/2
24	1732030SM	1	GUIDE, Hood, L.H.
25	1732031SM	1	GUIDE, Hood, R.H.
26	1735878YP	2	BRAID, Steel Insert
27	1727280ASM	1	HINGE, Hood, R.H.
28	1735879YP	1	BUMPER, Front
30	1735868YP	4	CAPSCREW, M8 x 40
31	1735989YP	4	WASHER, 8.4
32	1736000YP	4	WASHER, 8
33	1735934YP	4	NUT, M8
34	1731971SM	1	EDGING, Rubber
35	1741764MA	1	INSERT, Grille, R.H.
36	1741762MA	1	INSERT, Grille, Center
37	1741763MA	1	INSERT, Grille, L.H.
38	028X83MA	6	S-CLIP

### Footnotes

The above parts group applies to the following Mfg. Nos.:

2690891 - LT150RDFR

2690916 - LT150RD

## Seat Deck & Fuel Tank Group

NOTE: Unless noted otherwise,  
use the standard hardware torque  
specification chart.

2988878

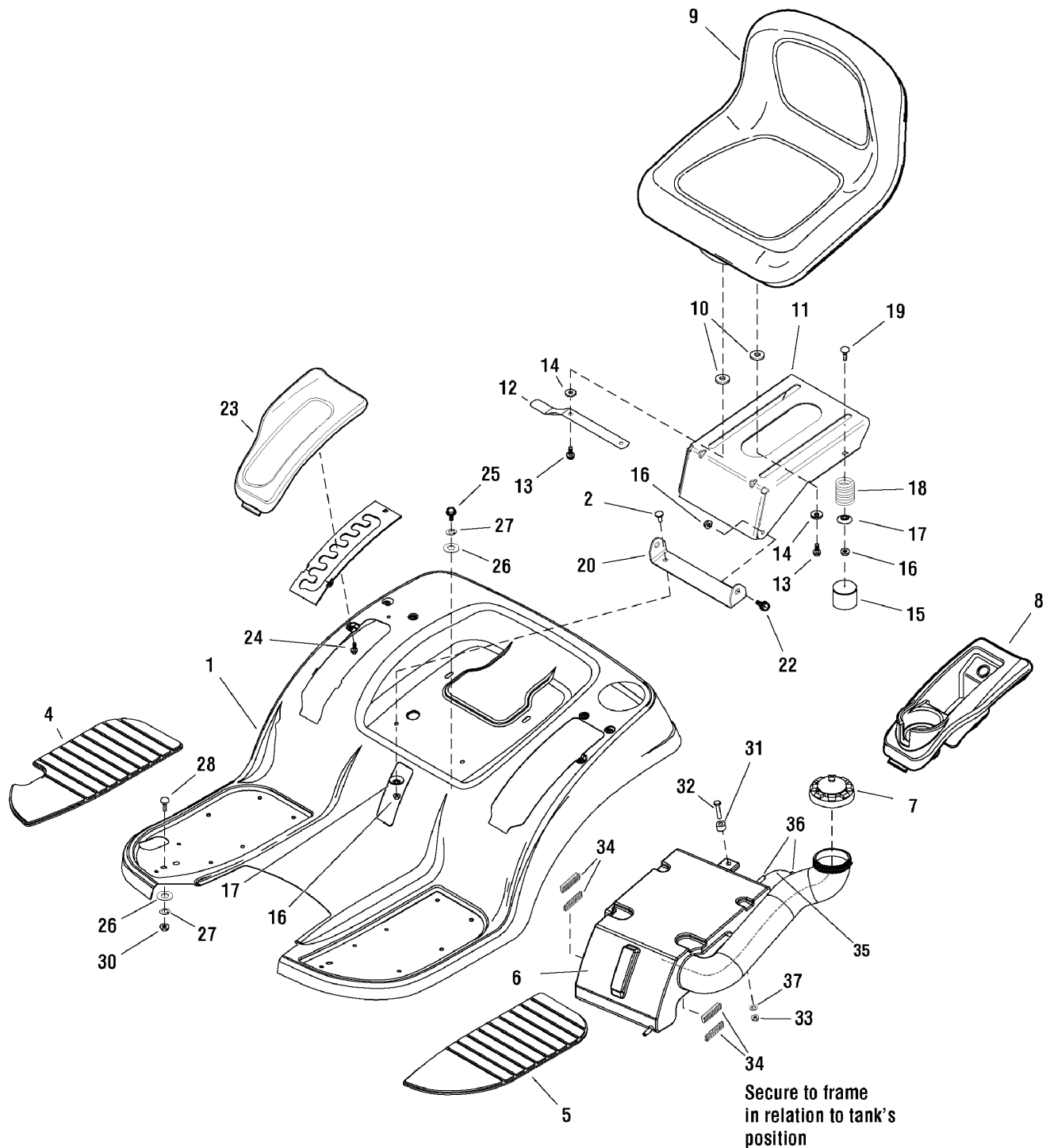

The above parts group applies to the following Mfg. Nos.:

2690891 - LT150RDFR

2690916 - LT150RD

## Seat Deck & Fuel Tank Group

REF NO	PART NO.	QTY.	DESCRIPTION
1	1735295BIYP	1	SEAT DECK, Black
2	1931333SM	2	BOLT-Round Head Shoulder, 5/16-18 x 3/4
4	1728007SM	1	PAD, Footrest, R.H.
5	1728006SM	1	PAD, Footrest, L.H.
6	1735976YP	1	TANK, Fuel
7	1715917SM	1	CAP, Fuel Tank
8	1739536YP	1	POD, L.H.
9	1730159SM	1	SEAT
10	1731300SM	4	SPACER, 5/16 ID x 1-1/4 OD x 5/16
11	1727265ASM	1	SUPPORT, Seat
12	1727268AYP	1	LATCH, Seat
13	1960667SM	4	CAPSCREW, Hex Flange Whiz Lock, Dog Point, 5/16-18 x 1
14	1919381SM	4	WASHER, 5/16
15	1704724SM	2	COVER, Spring
16	1960686SM	6	NUT, Hex Flange, ESNA, 5/16-18
17	1709256SM	4	WASHER, Spring
18	1704728SM	2	SPRING, Compression
19	1960282SM	2	BOLT, Carriage, 5/16-18 x 3/4
20	1727266ASM	1	PIVOT, Seat
22	1729576SM	2	BOLT, Shoulder, 5/16-18 x 1-1/8
23	1739538YP	1	POD, R.H.
24	1960536SM	6	CAPSCREW, Hex Washer Head, Plastite, 1/4 x 1/2
25	1735854YP	2	BOLT, M8 x 16
26	1735989YP	4	WASHER, 8.4
27	1736000YP	4	WASHER, 8
28	1735869YP	2	BOLT, M8 x 20
30	1735937YP	2	NUT, M8
31	1735894YP	1	DISTANCE, Lift
32	1735867YP	1	BOLT, M6 x 30
33	1735932YP	1	NUT, M6
34	1735878YP	4	BRAID, Steel Insert
35	1735914YP	1	HOSE, Air Escape
36	1736993YP	2	CLAMP
37	1735999YP	1	WASHER, 6.6

### Footnotes

The above parts group applies to the following Mfg. Nos.:

2690891 - LT150RDFR

2690916 - LT150RD

## Mulching Group

NOTE: Unless noted otherwise,  
use the standard hardware torque  
specification chart.

2988026

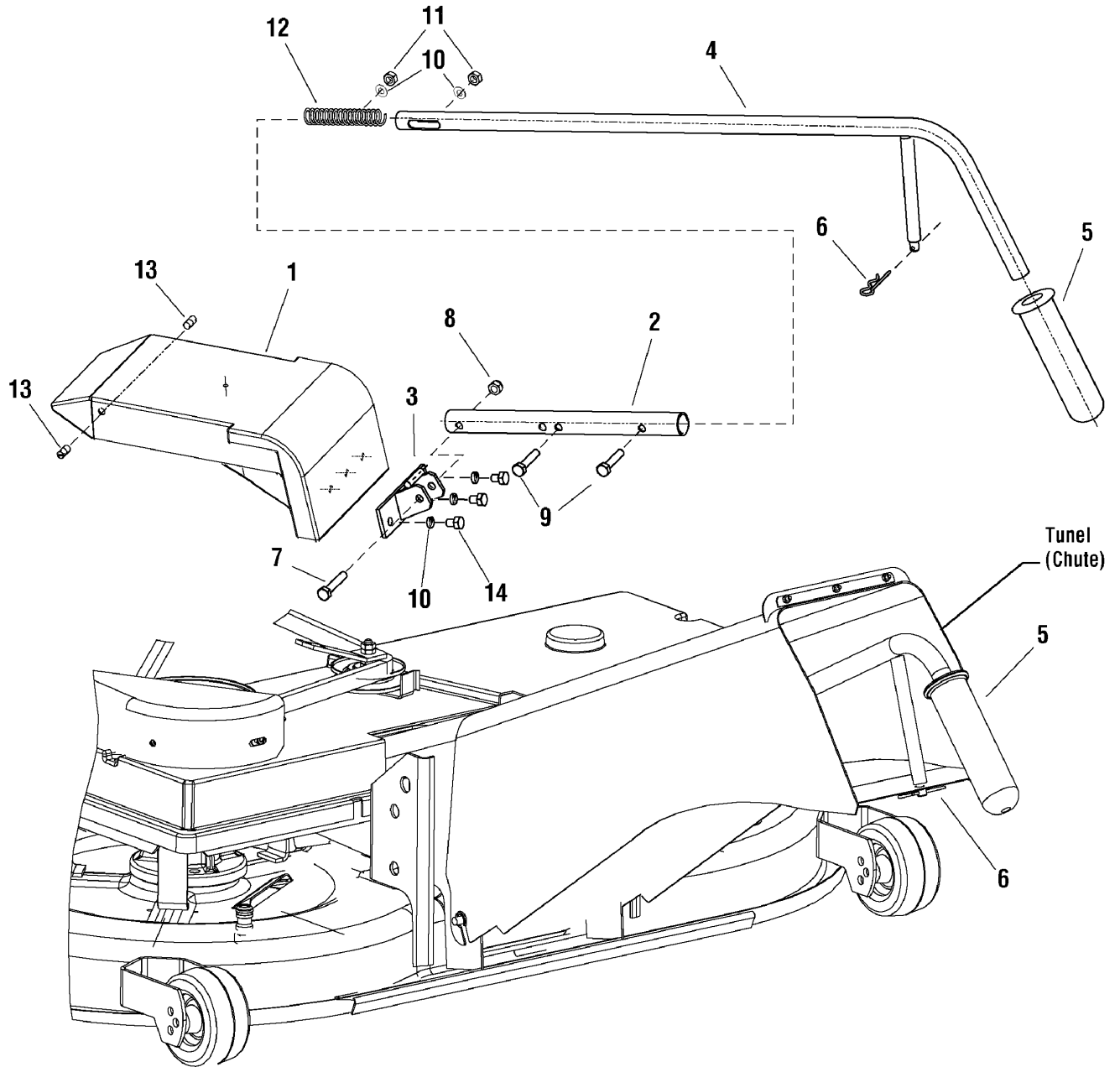

The above parts group applies to the following Mfg. Nos.:

2690891 - LT150RDFR

2690916 - LT150RD

## **Mulching Group**

---

<b>REF NO</b>	<b>PART NO.</b>	<b>QTY.</b>	<b>DESCRIPTION</b>
1	1736134YP	1	FLANGE, Mowing 9-8547-386
2	1736133YP	1	TUBE
3	1736132YP	1	HOLDER
4	1736131YP	1	FULL TUBE
5	1736130YP	1	HANDLE
6	1736129YP	1	SPLIT PIN
7	1736128YP	1	SCREW, M8 x 45
8	1736127YP	1	NUT, M8
9	1736126YP	2	SCREW, M8 x 35
10	1736125YP	5	WASHER, 8
11	1736124YP	2	NUT, M8
12	1736123YP	1	SPRING
13	1736122YP	2	CASING
14	1736121YP	3	SCREW, M8 x 12

### **Footnotes**

---

**The above parts group applies to the following Mfg. Nos.:**

2690891 - LT150RDFR

2690916 - LT150RD

## Rear Discharge Deflector Group

NOTE: Unless noted otherwise,  
use the standard hardware torque  
specification chart.

1687401

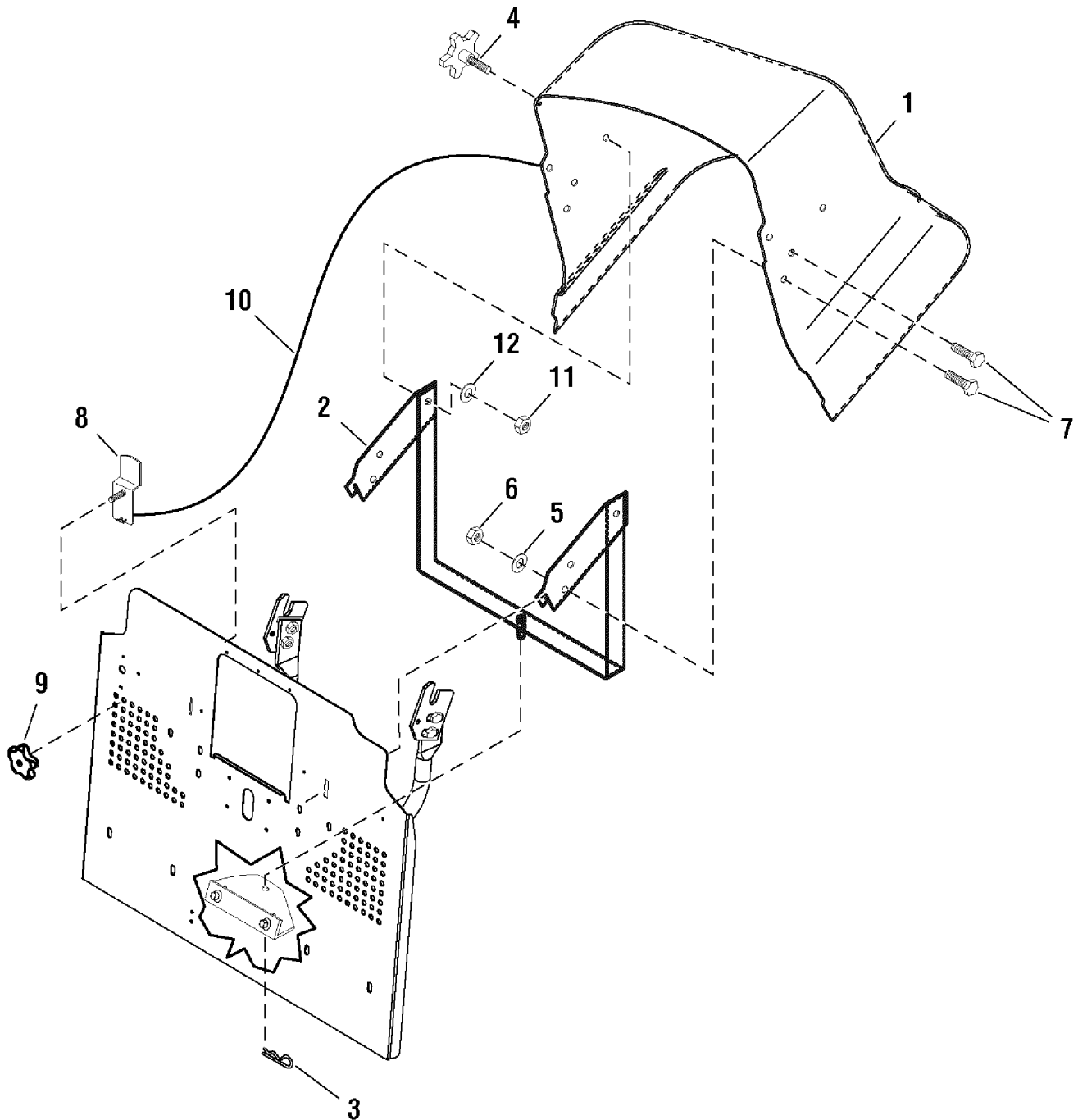

The above parts group applies to the following Mfg. Nos.:

2690891 - LT150RDFR

2690916 - LT150RD

## **Rear Discharge Deflector Group**

<b>REF NO</b>	<b>PART NO.</b>	<b>QTY.</b>	<b>DESCRIPTION</b>
--	1687401YP	1	DEFLECTOR, Complete
1	1739710YP	1	DEFLECTOR
2	1739711YP	1	DEFLECTOR HOLDER
3	1739716YP	1	HARI PIN
4	1739712YP	2	SCREW, With Starlike Knob
5	1735998YP	4	WASHER, 6.4
6	1736127YP	4	NUT, Selflock, M6
7	1732635YP	4	SCREW, Flat Head, M6 x 16
8	1739713YP	1	BAND
9	1739714YP	1	NUT, With Starlike Knob
10	1739715YP	1	CORD, Hair Line, 550mm
11	1735935SM	2	NUT, M8
12	1735989YP	2	WASHER, 8.4

### **Footnotes**

---

**The above parts group applies to the following Mfg. Nos.:**

2690891 - LT150RDFR

2690916 - LT150RD

# Lift Group

NOTE: Unless noted otherwise,  
use the standard hardware torque  
specification chart.

2988020

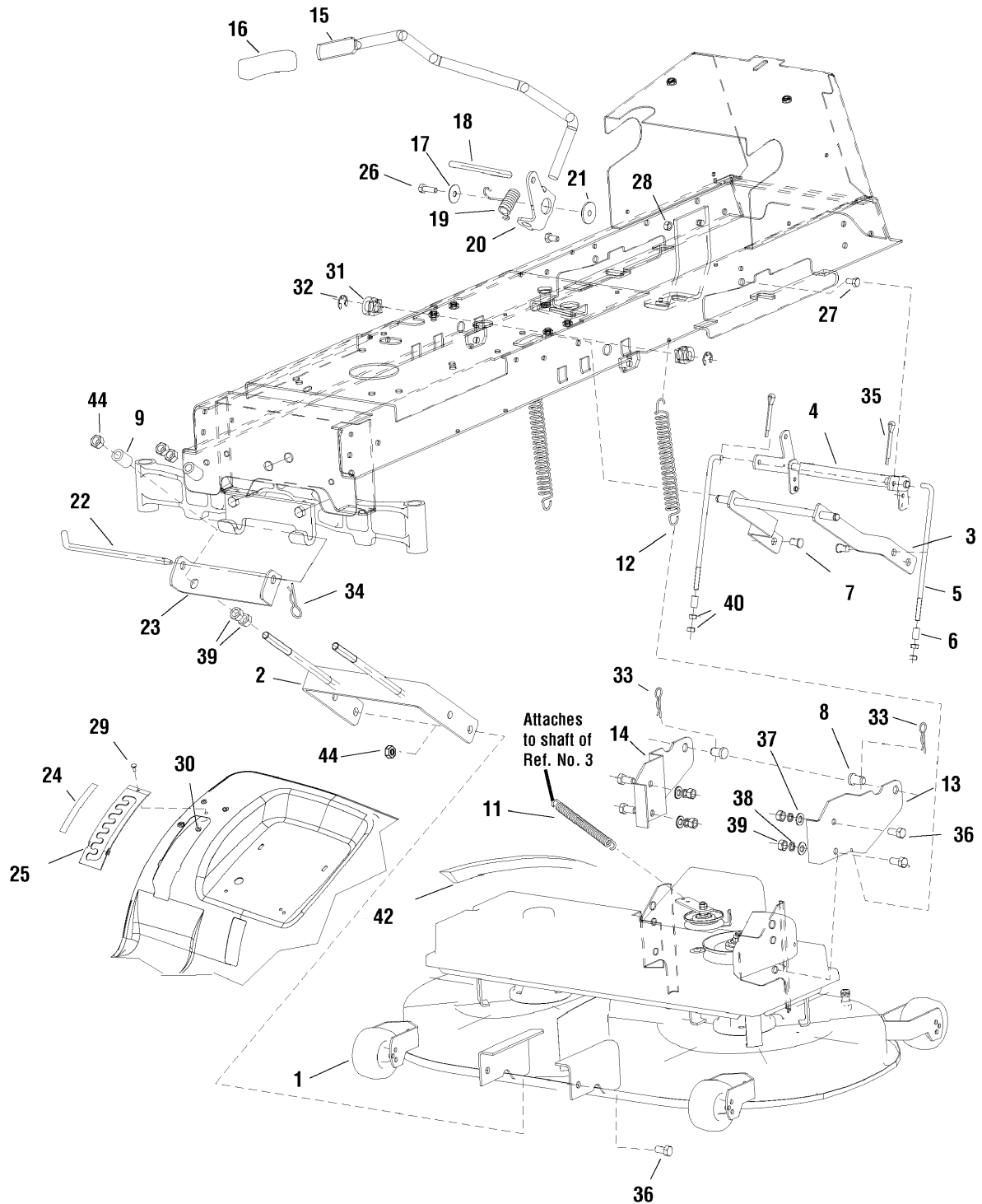

The above parts group applies to the following Mfg. Nos.:

2690891 - LT150RDFR

2690916 - LT150RD

## Lift Group

REF NO	PART NO.	QTY.	DESCRIPTION
1	1735923YP	1	MOWING MECHANISM
2	1735902YP	1	HINGE, Front
3	1735848YP	1	ARM, Lift
4	1735958YP	1	ROD, Lift
5	1735979YP	2	TIE ROD, Lift
6	1735893YP	2	DISTANCE, Lift
7	1735945YP	2	PIN, 0-9016-463
8	1735947YP	2	PIN, Mowing 1-9310-417
9	1735895YP	2	DISTANCE, Lift Hitch 0-9521-290
11	1735825YP	1	SPRING, 0-9746-460
12	1735967YP	2	SPRING, 0-9746-483
13	1735898YP	1	HANDLE, Extend, Left
14	1735899YP	1	HANDLE, Extend, Right
15	1735956YP	1	ROD, Lift -Change
16	1722302SM	1	GRIP, Black
17	1960044SM	1	WASHER, 0.312
18	1727954SM	1	ROD, Lift .375 dia
19	1729652SM	1	SPRING, Torsion
20	1728990SM	1	CLEVIS, Lift
21	1727935SM	1	SPACER, Pivot
22	1731414SM	1	PIN, Hitch
23	1730221ASM	1	HANGER, Front
24	1730264SM	1	DECAL, Height of Cut
25	1727985SM	1	QUADRANT, Lift Height
26	1921333SM	1	CAPSCREW, 5/16-18 x 1
27	1930601SM	2	CAPSCREW, Taptite, 5/16-18 x 5/8
28	1931277SM	1	NUT, Hex Flange, 5/16-18
29	1960252SM	1	BOLT, 1/4-20 x 5/8
30	1930641SM	1	NUT, Hex Flange, Whiz 1/4-20
31	1735881YP	2	BUSHING, 0-9462-202
32	1735920YP	2	LOCKRING, 12
33	1735965YP	2	PIN, Flexible 0-9245-240
34	2176012SM	1	CLIP, Pin Safety
35	1735964YP	4	SPINDLE, 3.2 x 25
36	1735856YP	4	BOLT, M12 x 25
37	1735993YP	4	WASHER, 13
38	1735992YP	4	WASHER, 12
39	1735927YP	8	NUT, M12
40	1735925YP	4	NUT, M10
42	1735986YP	1	V-Belt, Li, BBT, 17 x 1200
44	1735796YP	4	NUT, M12

## Footnotes

The above parts group applies to the following Mfg. Nos.:

2690891 - LT150RDFR

2690916 - LT150RD

## Wheels & Tires Group

NOTE: Unless noted otherwise,  
use the standard hardware torque  
specification chart.

2988024

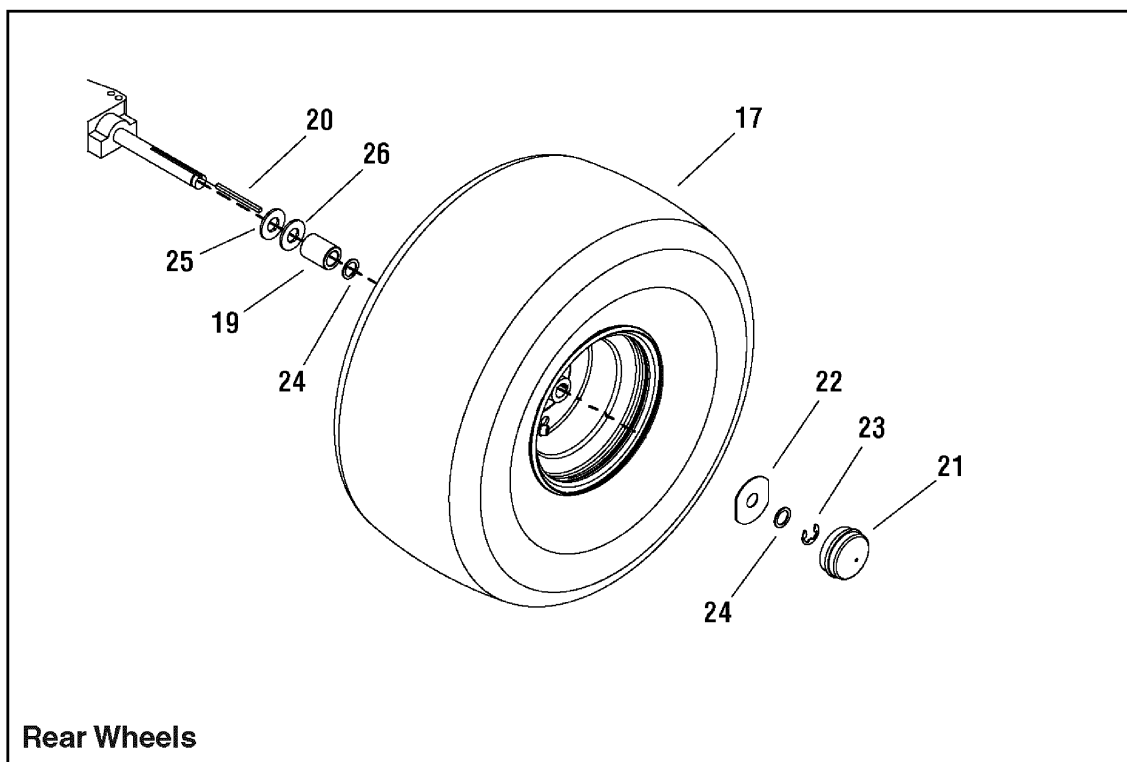
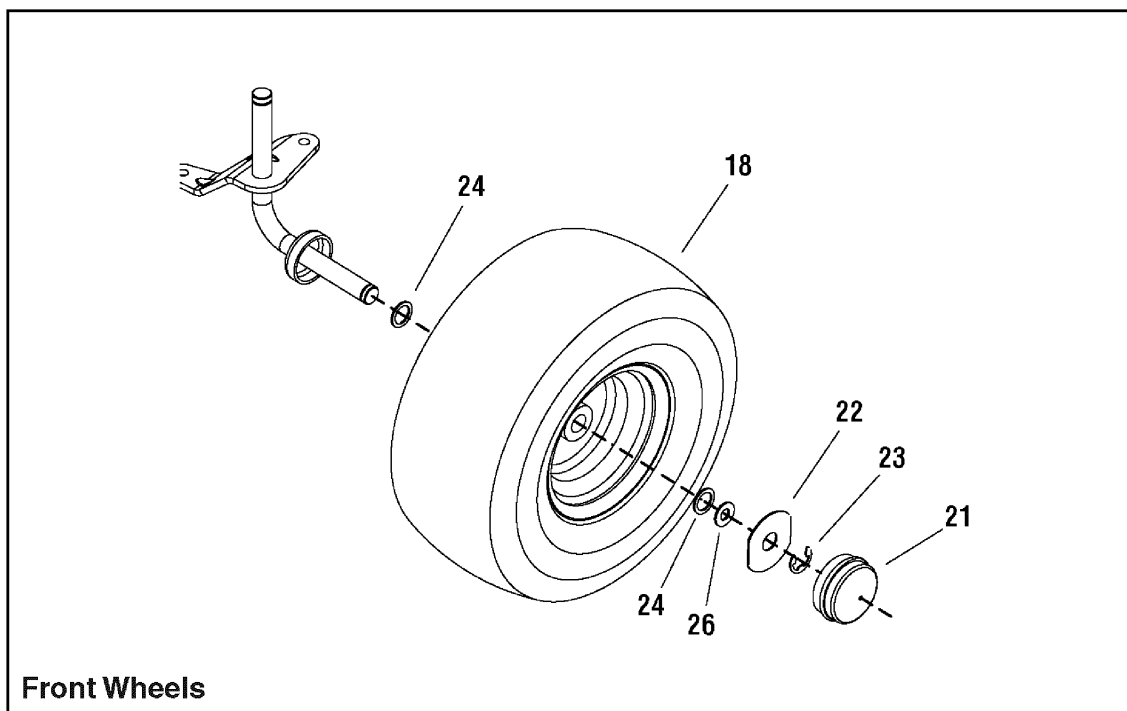

The above parts group applies to the following Mfg. Nos.:

2690891 - LT150RDFR

2690916 - LT150RD

## **Wheels & Tires Group**

---

<b>REF NO</b>	<b>PART NO.</b>	<b>QTY.</b>	<b>DESCRIPTION</b>
17	1732324SM	2	WHEEL AND TIRE ASSEMBLY, Rear, 22 x 10 - 8
18	1729708SM	2	WHEEL AND TIRE ASSEMBLY, Front, 14.4 x 6
19	1730181SM	2	SPACER, Axle, Rear PM Hunter
20	1713409SM	2	KEY, Parallel PLN .187 x .187 x 3.0 STL
21	1722676SM	4	HUB CAP
22	1722717SM	4	WASHER, 2-1/2
23	2827794SM	4	RING, Klipring EXT For .75 Dia Shaft blk
24	1960160SM	8	WASHER, 1-5/8
25	2860202SM	2	WASHER, 3/4
26	1735988YP	8	WASHER, 3/4

### **Footnotes**

---

**The above parts group applies to the following Mfg. Nos.:**

2690891 - LT150RDFR

2690916 - LT150RD

## Decal Group

NOTE: Unless noted otherwise,  
use the standard hardware torque  
specification chart.

2988877

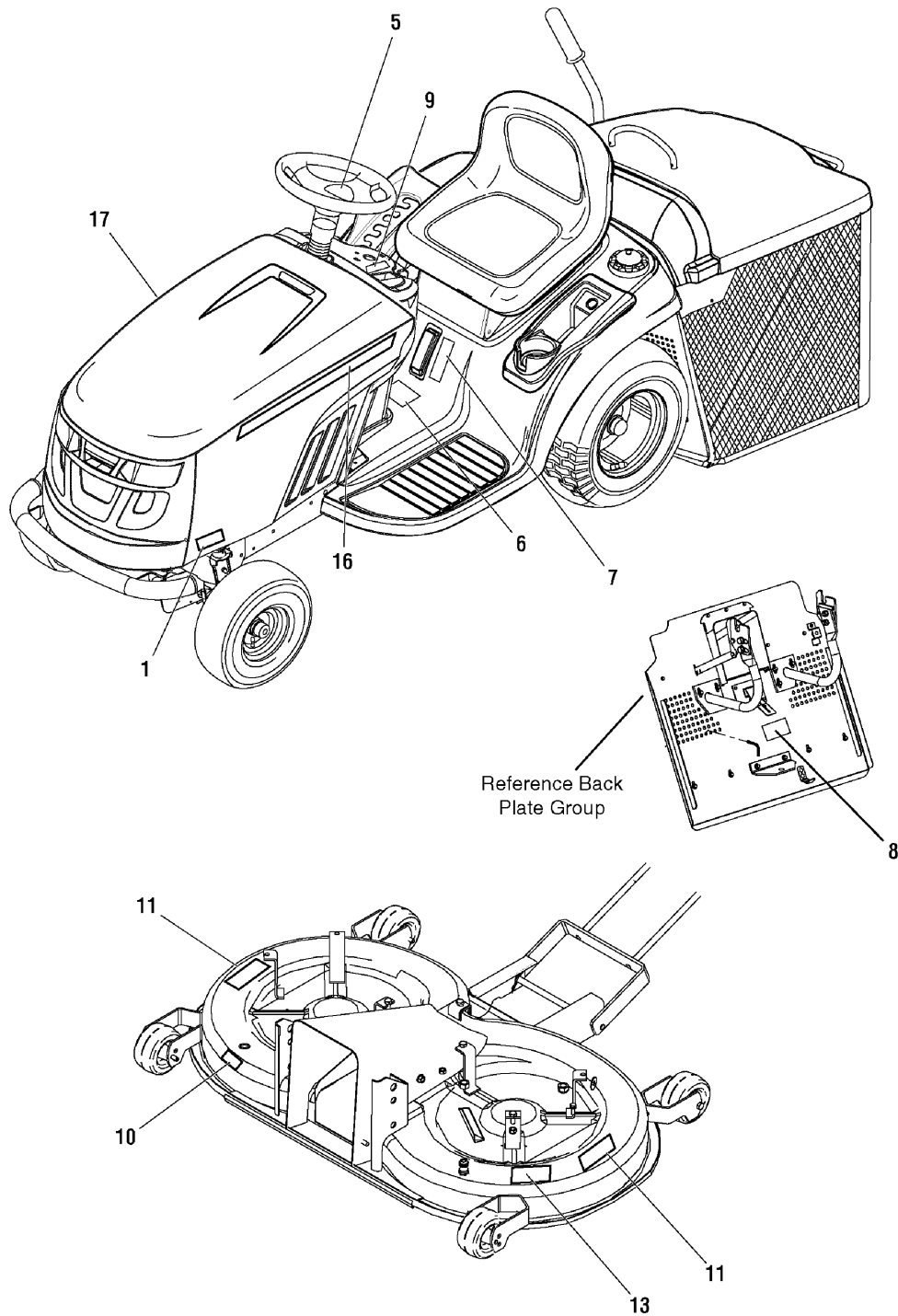

The above parts group applies to the following Mfg. Nos.:

2690891 - LT150RDFR

2690916 - LT150RD

## **Decal Group**

---

<b>REF NO</b>	<b>PART NO.</b>	<b>QTY.</b>	<b>DESCRIPTION</b>
1	1739667YP	2	DECAL, LT180RD
5	1737167YP	1	DECAL, Steering Wheel
6	1734027SM	1	DECAL, Tunnel Cover Warnings, Export
7	1735889YP	1	DECAL, Fuel Level
8	1735265SM	1	DECAL, Hydro Release
9	1722806SM	1	DECAL, Ignition Switch Symbols
10	1735891YP	1	DECAL, Noise
11	1735890YP	2	DECAL, Safety
13	1737183YP	1	DECAL, Murray 102cm
16	1739088YP	1	DECAL, Murray, L.H.
17	1739087YP	1	DECAL, Murray, R.H.

## **Footnotes**

---

**The above parts group applies to the following Mfg. Nos.:**

2690891 - LT150RDFR

2690916 - LT150RD

## Back Plate Group

2988766

NOTE: Unless noted otherwise,  
use the standard hardware torque  
specification chart.

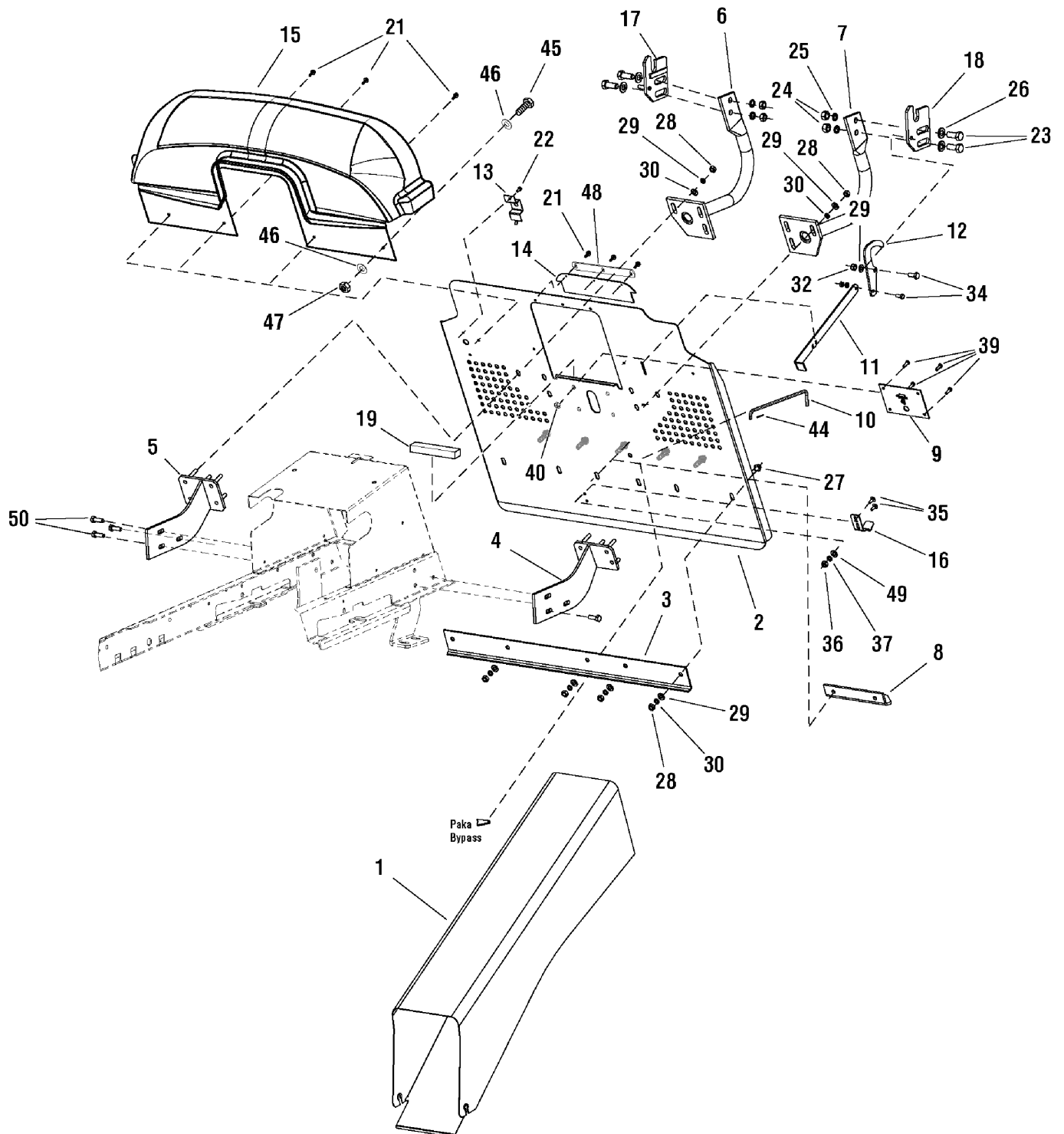

The above parts group applies to the following Mfg. Nos.:

2690891 - LT150RDFR

2690916 - LT150RD

## Back Plate Group

REF NO	PART NO.	QTY.	DESCRIPTION
1	1735985YP	1	TUNNEL
2	1735849YP	1	BACKPLATE
3	1735876YP	1	BRACE
4	1735906YP	1	HOLDER, Back Plate, L.H.
5	1735907YP	1	HOLDER, Back Plate, R.H.
6	1735908YP	1	HOLDER, Collector, R.H.
7	1735909YP	1	HOLDER, Collector, L.H.
8	1735903YP	1	HITCH
9	1735975YP	1	SWITCH, Full Collector
10	1735977YP	1	TIE ROD, Bypass
11	1735978YP	1	TIE ROD, Latch
12	1735915YP	1	LATCH
13	1735887YP	1	COVER, Switch
14	1735939YP	1	PAD, Rubber
15	1735983YP	1	TRANSITION PART
16	1735970YP	1	SPRING, Collector Lock
17	1735904YP	1	HOLDER, Adjustable, R.H.
18	1735905YP	1	HOLDER, Adjustable, L.H.
19	1736998YP	1	RUBBER EDGE
21	1735961YP	6	CAPSCREW, Self Tap, 5,5 x 19
22	1735960YP	1	CAPSCREW, Self Tap, 4.2 x 9.5
23	1735857YP	4	BOLT, M12 x 30
24	1735927YP	4	NUT, M12
25	1735993YP	4	WASHER, 13
26	1735992YP	4	WASHER, 12
27	1735871YP	6	BOLT, M8 x 25 DIN 6921 8.8
28	1735934YP	12	NUT, M8
29	1735989YP	14	WASHER, 8.4
30	1736000YP	12	WASHER, 8
32	1735935YP	2	NUT, M8
34	1735868YP	2	CAPSCREW, M8 x 40
35	1735860YP	2	BOLT, M5 x 16
36	1735930YP	2	NUT, M5
37	1735997YP	2	WASHER, 5.3
39	1735861YP	4	BOLT, M5 x 16
40	1735931YP	4	NUT, M5
44	1735963YP	1	SPINDLE
45	1735858YP	1	BOLT, M4 x 16
46	1735995YP	2	WASHER, 4.3
47	1735929YP	1	NUT, M4
48	1739133YP	1	PAD, Steel
49	1739134YP	2	WASHER, 8,4
50	1930601SM	6	CAPSCREW, Hex Washer Head, Taptite, 5/16-18 x 5/8

### Footnotes

The above parts group applies to the following Mfg. Nos.:

2690891 - LT150RDFR

2690916 - LT150RD

## Collector Group

NOTE: Unless noted otherwise,  
use the standard hardware torque  
specification chart.

2988882



The above parts group applies to the following Mfg. Nos.:

2690891 - LT150RDFR

2690916 - LT150RD

## Collector Group

REF NO	PART NO.	QTY.	DESCRIPTION
1	1735897YP	1	FRAME, Top
2	1736463YP	1	TUBE, Front
3	1735877YP	2	BRACE
4	1735984YP	1	TUBE, Bottom
5	1735953YP	1	REINFORCEMENT, L.H.
6	1736236YP	1	REINFORCEMENT, L.H.
7	1735954YP	1	REINFORCEMENT, R.H.
8	1735900YP	1	HANDLE, FULL
9	1735885YP	1	COAT, Fabric
10	1739670YP	1	TOP COLLECTOR
11	1735916YP	1	LEVER DUMPING
12	1735901YP	1	HANDLE, Rubber
13	1735859YP	1	BOLT, M5 x 12
14	1735860YP	6	BOLT, M5 x 16
15	1735948YP	1	PLUG
16	1735863YP	2	BOLT, M5 x 30
17	1735864YP	2	BOLT, M5 x 35
18	1735990YP	2	WASHER, 10.5
19	1735991YP	2	WASHER, 10.5
20	1735925YP	2	NUT, M10
21	1735868YP	2	CAPSCREW, M8 x 40
22	1735989YP	2	WASHER, 8.4
23	1736000YP	2	WASHER, 8
24	1735934YP	2	NUT, M8
25	1735997YP	14	WASHER, 5.3
26	1735931YP	15	NUT, M5
27	1735862YP	4	BOLT, M5 x 25
28	1735971YP	1	SPRING, Flat
29	1735955YP	1	REINFORCEMENT, Top
31	1736416YP	6	CAPSCREW, 6.3 x 32

## Footnotes

---

**The above parts group applies to the following Mfg. Nos.:**

2690891 - LT150RDFR

2690916 - LT150RD

## French Guard Group

NOTE: Unless noted otherwise,  
use the standard hardware torque  
specification chart.

2988189

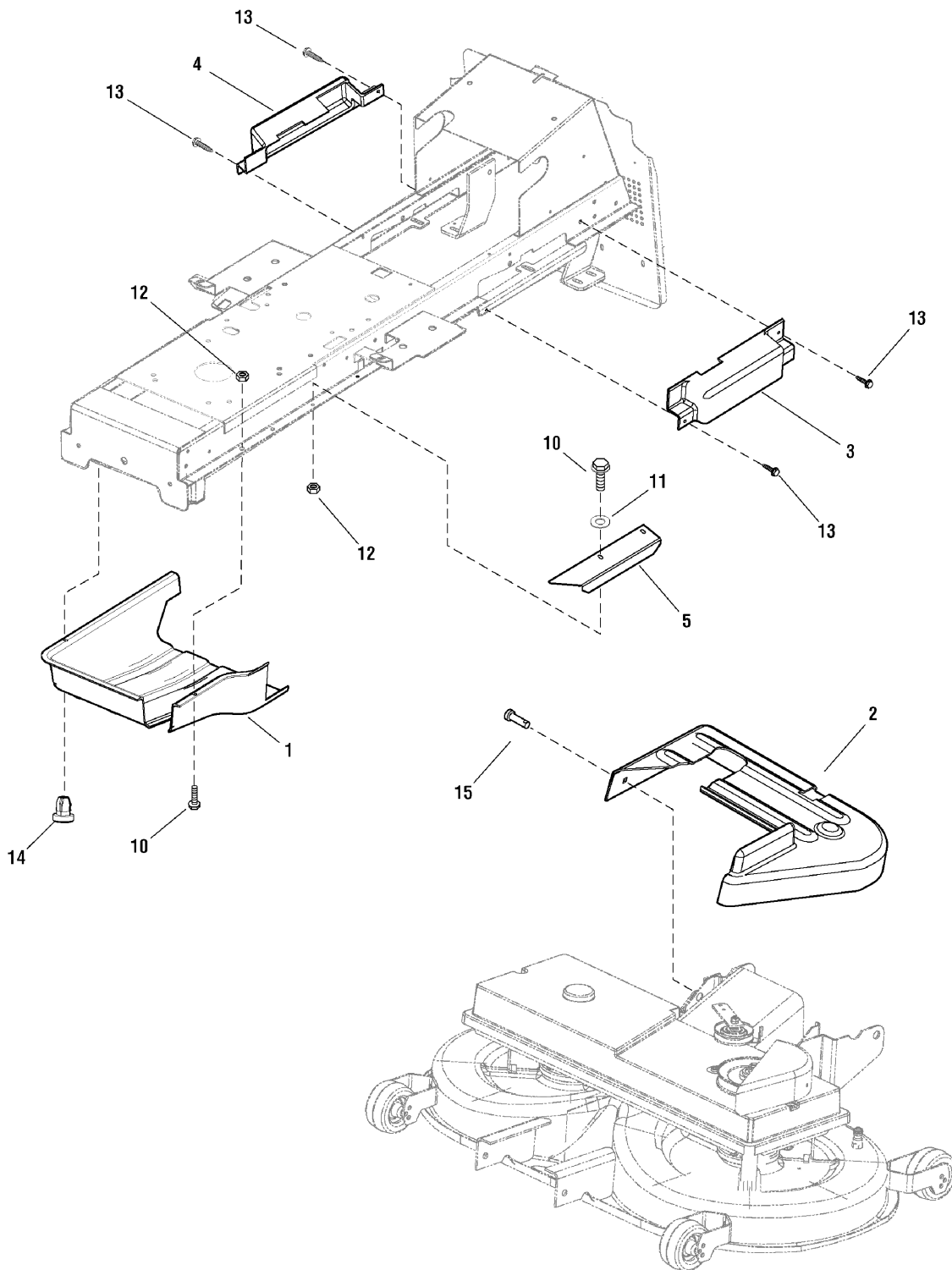

The above parts group applies to the following Mfg. Nos.:

2690891 - LT150RDFR

## ***French Guard Group***

---

<b>REF NO</b>	<b>PART NO.</b>	<b>QTY.</b>	<b>DESCRIPTION</b>
1	1737360YP	1	COVER, Clutch
2	1737361YP	1	COVER, Mower Deck
3	1737362YP	1	COVER, Roller, L.H.
4	1737363YP	1	COVER, Roller, R.H.
5	1737364YP	1	COVER, Side
10	1735859YP	6	BOLT, M5 x 12
11	1735997YP	2	WASHER, 5.3
12	1735931YP	6	NUT, M5
13	1735961YP	4	CAPSCREW, Self Tap, 5,5 x 19
14	1737365YP	2	HOUSING
15	1737366YP	2	PIN

### **Footnotes**

---

**The above parts group applies to the following Mfg. Nos.:**

2690891 - LT150RDFR

## 40" Mower Deck - Belt & Idler Arm Group

2988004

NOTE: Unless noted otherwise,  
use the standard hardware torque  
specification chart.

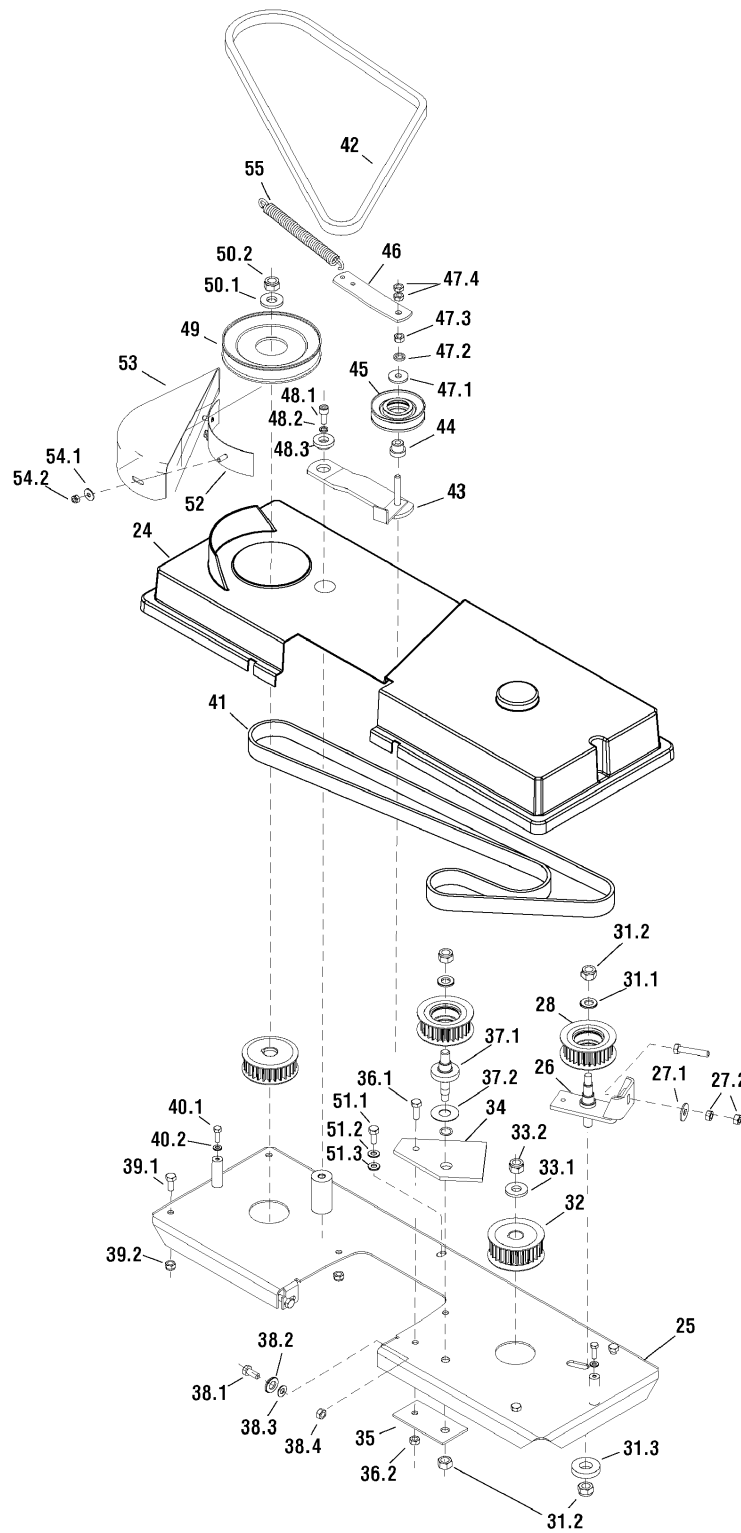

The above parts group applies to the following Mfg. Nos.:

2690891 - LT150RDFR

2690916 - LT150RD

## 40" Mower Deck - Belt & Idler Arm Group

REF NO	PART NO.	QTY.	DESCRIPTION
24	1735802YP	1	COVER, Plastic 0-8547-369
25	1735794YP	1	MAIN BOARD
26	1735787YP	1	FOOTING, Complete
27.1	1735846YP	1	WASHER, Zinc, 9
27.2	1735799YP	2	NUT, M8
28	1735781YP	2	PULLEY, Belt 28 Z
31.1	1735837YP	2	WASHER, 13
31.2	1735796YP	4	NUT, M12
31.3	1735842YP	1	WASHER
32	1735784YP	2	PULLEY, Belt
33.1	1735834YP	1	WASHER, 0-9220-727
33.2	1735796YP	1	NUT, M12
34	1735804YP	1	REINFORCEMENT
35	1735805YP	1	REINFORCEMENT
36.1	1735818YP	1	SCREW, M8 x 25
36.2	1735801YP	1	NUT, M8
37.1	1735827YP	1	STUD
37.2	1735841YP	1	WASHER
38.1	1735843YP	2	SCREW, Zinc M8 x 20
38.2	1735837YP	2	WASHER, 13
38.3	1735839YP	2	WASHER, 8.4
38.4	1735801YP	2	NUT, M8
39.1	1735820YP	6	SCREW, M8 x 40
39.2	1735801YP	6	NUT, M8
40.1	1735816YP	2	SCREW, M6 x 20
40.2	1735844YP	6	WASHER, Zinc, 6.6
41	1735832YP	1	BELT, Two Side Tooth K+K20DS 1760
42	1735986YP	1	V-BELT, Li, BBT, 17 x 1200
43	1735790YP	1	HOLDER, Complete
44	1735826YP	1	STUD, 0-9321-263
45	1735811YP	1	ROLLER, W 3500-3712
46	1737369YP	1	FOOTING
47.1	1735845YP	1	WASHER, Zinc, 9
47.2	1735838YP	1	WASHER, 8
47.3	1735799YP	1	NUT, M8
47.4	1735800YP	2	NUT, M8
48.1	1735817YP	1	SCREW, M8 x 20 10.9 ZN DIN 912
48.2	1735838YP	1	WASHER, 8
48.3	1735836YP	1	WASHER, 0-9221-222
49	1735782YP	1	PULLEY, Belt 9-3325-234, Complete
50.1	1735834YP	1	WASHER, 0-9220-727
50.2	1735796YP	1	NUT, M12
51.1	1735820YP	1	SCREW, M 8 x 40

### Footnotes

The above parts group applies to the following Mfg. Nos.:

2690891 - LT150RDFR

2690916 - LT150RD

## 40" Mower Deck - Belt & Idler Arm Group

2988004

NOTE: Unless noted otherwise,  
use the standard hardware torque  
specification chart.

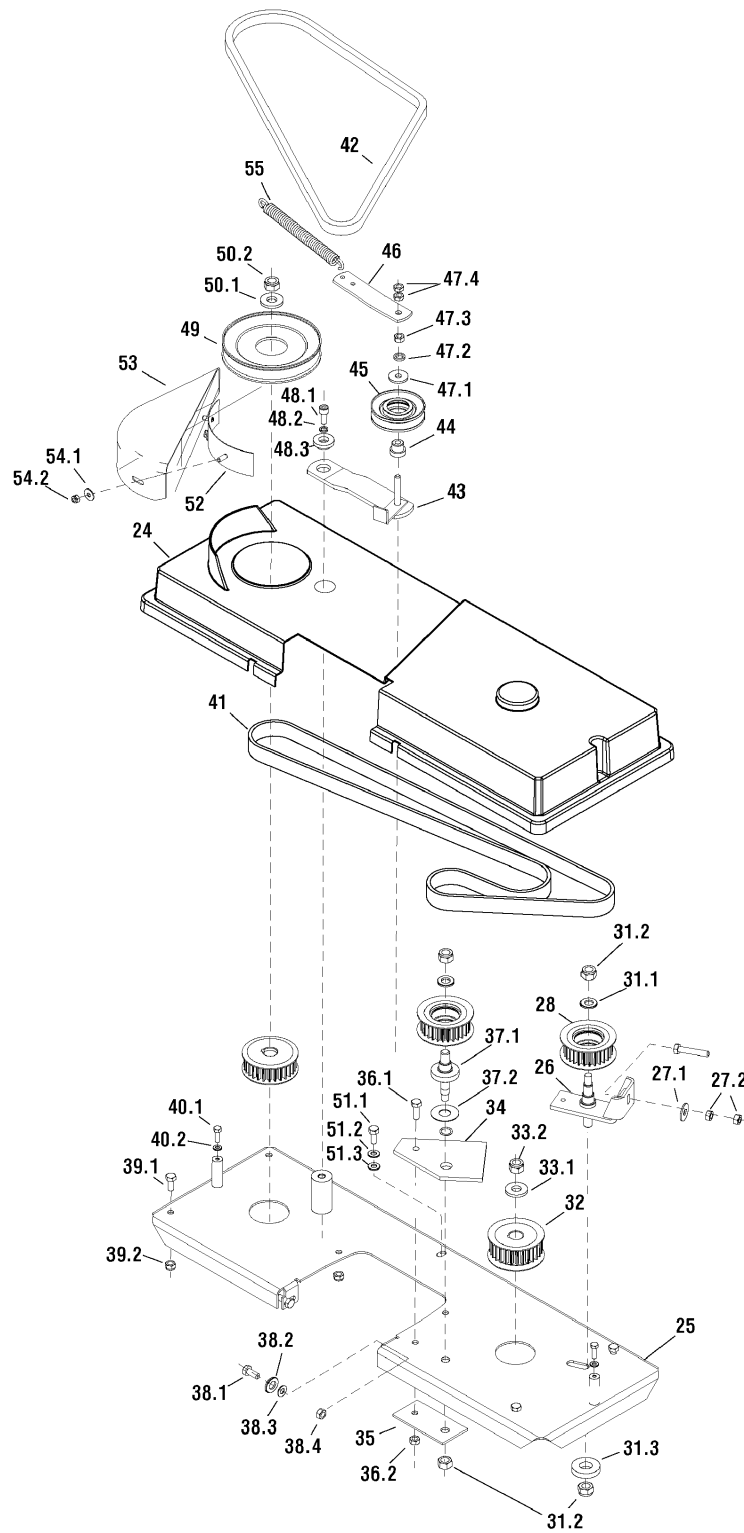

The above parts group applies to the following Mfg. Nos.:

2690891 - LT150RDFR

2690916 - LT150RD

## **40" Mower Deck - Belt & Idler Arm Group**

---

<b>REF NO</b>	<b>PART NO.</b>	<b>QTY.</b>	<b>DESCRIPTION</b>
53	1735783YP	1	COVER, Pulley, Belt 0-8534-203
54.1	1735844YP	2	WASHER, Zinc, 6.6
54.2	1735798YP	2	NUT, M6
55	1935825YP	1	SPRING, 0-9746-460

---

### **Footnotes**

---

**The above parts group applies to the following Mfg. Nos.:**

2690891 - LT150RDFR

2690916 - LT150RD

# 40" Mower Deck - Housing, Hitch, Arbors & Blade Group

2988005

NOTE: Unless noted otherwise,  
use the standard hardware torque  
specification chart.

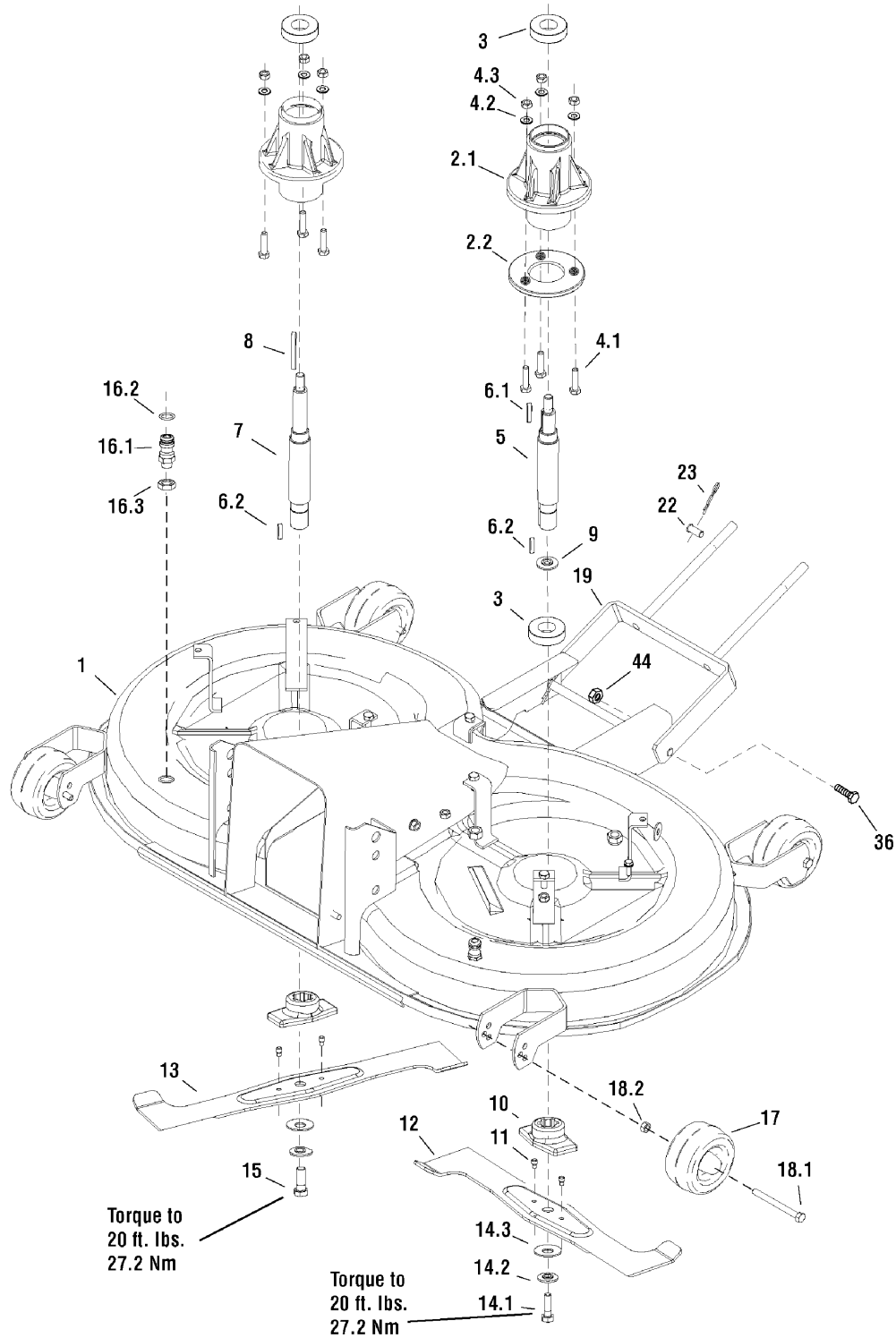

The above parts group applies to the following Mfg. Nos.:

2690891 - LT150RDFR

2690916 - LT150RD

## 40" Mower Deck - Housing, Hitch, Arbors & Blade Group

REF NO	PART NO.	QTY.	DESCRIPTION
1	1737368YP	1	MOWER DECK, Complete
2.1	1735791YP	2	HOUSING
2.2	1735807YP	2	REINFORCEMENT
3	1735780YP	4	BEARING, 6205 2 RS C 661B
4.1	1735819YP	6	SCREW, M8 x 35
4.2	1735839YP	6	WASHER, 8.4
4.3	1735801YP	6	NUT, M8
5	1735823YP	1	SHAFT
6.1	1735830YP	1	TONGUE, 6 H 9 x 6 x 30
6.2	1735829YP	2	TONGUE, 6 H 9 x 6 x 25
7	1735822YP	1	SHAFT
8	1735831YP	1	TONGUE, 6 H 9 x 6 x 63
9	1735812YP	2	RING, Safety 25
10	1735792YP	2	HOUSING
11	1735824YP	4	SHEAR STUD, 0-9311-736
12	1735809YP	1	BLADE, Right Rotary
13	1735793YP	1	BLADE, Left Rotary
14.1	1735815YP	1	SCREW, M10, 0-9011-287
14.2	1735835YP	2	WASHER, 0-9220-749
14.3	1735840YP	2	WASHER, BN 806-40 x 16.3 x 2 x 3.1
15	1735814YP	1	SCREW, 0-9011-283 M10, Left Thread
16.1	1735803YP	2	QUICK FASTENER, 0-9026-246
16.2	1735810YP	2	RING, 13 x 2 NBR
16.3	1735797YP	2	NUT, M12
17	1735808YP	4	CUTTING WHEEL, Right ETOP 100-8.2
18.1	1735821YP	4	SCREW, M8 x 90
18.2	1735801YP	4	NUT, M8
19	1735902YP	1	HINGE, Front
22	1735795YP	2	MOWING STUD, 1-9310-290
23	1735786YP	4	PIN, Flexible 0-9245-999
36	1735856YP	2	BOLT, M12 x 25
44	1735796YP	2	NUT, M12

### Footnotes

---

The above parts group applies to the following Mfg. Nos.:

2690891 - LT150RDFR

2690916 - LT150RD







# Hardware Identification & Torque Specifications

Torque Specification Chart								
FOR STANDARD METRIC MACHINE HARDWARE (Tolerance ± 20%)								
Property Class	5.6		8.8		10.9		12.9	
	Class 5.6		Class 8.8		Class 10.9		Class 12.9	
Size Of Hardware	in/lbs		in/lbs		in/lbs		in/lbs	
	ft/lbs	Nm.	ft/lbs	Nm.	ft/lbs	Nm.	ft/lbs	Nm.
M3	5.88	.56	13.44	1.28	19.2	1.80	22.92	2.15
M4	13.44	1.28	30.72	2.90	43.44	4.10	52.56	4.95
M5	26.4	2.50	60.96	5.75	5.97	8.10	7.15	9.7
M6	44.64	4.3	7.3	9.9	10.3	14	12.1	16.5
M7	5.2	7.1	12.1	16.5	16.9	23	19.9	27
M8	7.7	10.5	17.7	24	25	34	29	40
M10	15	21	35	48	50	67	59	81
M12	26	36	61	83	86.2	117	103	140
M14	42	58	101	132	136	185	162	220
M16	64	88	147	200	210	285	250	340
M18	89	121	202	275	287	390	346	470
M20	126	171	290	390	405	550	486	660
M22	169	230	390	530	559	745	656	890
M24	217	295	497	375	708	960	840	1140
M27	320	435	733	995	1032	1400	1239	1680
M30	435	590	995	1350	1401	1900	1681	2280
M33	590	800	1349	1830	1902	2580	2278	3090
M36	759	1030	1740	2360	2441	3310	2935	3980
M39	988	1340	2249	3050	3163	4290	3798	5150

The guides and ruler furnished below are designed to help you select the appropriate hardware.



**Nut, M8**

Thread Diameter (mm)  
Inside Diameter (in)  
Threads per inch

**Nut, 1/2-16**

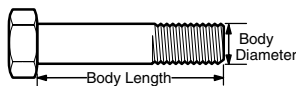

**Screw, M8- 1.25 x 25**

Thread Diameter (mm)  
Body Diameter  
Distance between threads (mm)  
Threads per inch  
Body Length (mm)  
Body Length (in)

**Screw, 1/2- 16 x 2**

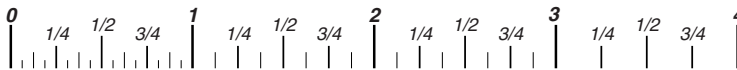

## Standard Hardware Sizing

When a washer or nut is identified as **1/2"** (M8), this is the *Nominal size*, meaning the *inside diameter* is 1/2 inch (8mm metric thread diameter); if a second number is present it represents the *threads per inch* (distance between threads).

When bolt or capscrew is identified as **1/2 - 16 x 2"** (M8 - 1.25 x 50 ), this means the *Nominal size*, or body diameter is 1/2 inch (8mm metric thread diameter), the second number, 16, represents the *threads per inch*, (*1.25 thread diameter*). The final number is the body length of the bolt or screw, 2 inches (50mm).

Torque Specification Chart						
FOR STANDARD MACHINE HARDWARE (Tolerance ± 20%)						
Hardware Grade	No Marks		SAE Grade 5		SAE Grade 8	
	SAE Grade 2		SAE Grade 5		SAE Grade 8	
Size Of Hardware	in/lbs		in/lbs		in/lbs	
	ft/lbs	Nm.	ft/lbs	Nm.	ft/lbs	Nm.
8-32	19	2.1	30	3.4	41	4.6
8-36	20	2.3	31	3.5	43	4.9
10-24	27	3.1	43	4.9	60	6.8
10-32	31	3.5	49	5.5	68	7.7
1/4-20	66	7.6	8	10.9	12	16.3
1/4-28	76	8.6	10	13.6	14	19.0
5/16-18	11	15.0	17	23.1	25	34.0
5/16-24	12	16.3	19	25.8	29	34.0
3/8-16	20	27.2	30	40.8	45	61.2
3/8-24	23	31.3	35	47.6	50	68.0
7/16-14	30	40.8	50	68.0	70	95.2
7/16-20	35	47.6	55	74.8	80	108.8
1/2-13	50	68.0	75	102.0	110	149.6
1/2-20	55	74.8	90	122.4	120	163.2
9/16-12	65	88.4	110	149.6	150	204.0
9/16-18	75	102.0	120	163.2	170	231.2
5/8-11	90	122.4	150	204.0	220	299.2
5/8-18	100	136	180	244.8	240	326.4
3/4-10	160	217.6	260	353.6	386	525.0
3/4-16	180	244.8	300	408.0	420	571.2
7/8-9	140	190.4	400	544.0	600	816.0
7/8-14	155	210.8	440	598.4	660	897.6
1-8	220	299.2	580	788.8	900	1,244.0
1-12	240	326.4	640	870.4	1,000	1,360.0

## NOTES

- These torque values are to be used for all hardware excluding: locknuts, self-tapping screws, thread forming screws, sheet metal screws and socket head setscrews.
- Recommended seating torque values for locknuts:
  - for prevailing torque locknuts - use 65% of grade 5 torques.
  - for flange whizlock nuts and screws - use 135% of grade 5 torques.
- Unless otherwise noted on assembly drawings, all torque values must meet this specification.

## Common Hardware Types

Hex Head Capscrew



Washer



Lockwasher

Carriage Bolt



Hex Nut

## Wrench & Fastener Size Guide

1/4" Bolt or Nut Wrench—7/16"	5/16" Bolt or Nut Wrench—1/2"	3/8" Bolt or Nut Wrench—9/16"	7/16" Bolt or Nut Wrench (Bolt)—5/8" Wrench (Nut)—11/16"	1/2" Bolt or Nut Wrench—3/4"
M6 Bolt or Nut Wrench—10mm	M8 Bolt or Nut Wrench—13mm	M10 Bolt or Nut Wrench—17mm	M12 Bolt or Nut Wrench—19mm	M14 Bolt or Nut Wrench—22mm

**IT IS THE POLICY OF BRIGGS & STRATTON CORP. TO IMPROVE ITS PRODUCTS  
WHENEVER IT IS POSSIBLE AND PRACTICAL TO DO SO. WE RESERVE THE RIGHT TO  
MAKE CHANGES OR ADD IMPROVEMENTS AT ANY TIME WITHOUT INCURRING ANY  
OBLIGATION TO MAKE SUCH CHANGES ON PRODUCTS.**

**Briggs & Stratton Yard Power Products Group**

---

3515 N. 124 Street / PO Box 702  
Wauwatosa, WI 53222 USA

[www.murray.com](http://www.murray.com)

© Copyright 2010 by Briggs & Stratton Corporation  
Milwaukee, WI, USA. All rights reserved